



# Airbar® Parts List Combine Mounted Fans

more **yield**  
from your **field**  
with air-assist harvesting

Contact Info:

**TEMP Farm Equipment Ltd.**  
3890 Wellington St. Box 269  
Mitchell, Ontario, Canada  
N0K-1N0  
Ph: 1-877-348-0066

**Parts:** Craig Rock [craigrock@awsairbar.com](mailto:craigrock@awsairbar.com)  
**Service:** Dave Miller [dmiller@awsairbar.com](mailto:dmiller@awsairbar.com)  
**Sales:** Zac Corbin [zcorbin@awsairbar.com](mailto:zcorbin@awsairbar.com)  
**Sales:** Carmen Drost [cdrost@awsairbar.com](mailto:cdrost@awsairbar.com)  
**Development:** Ian Brown [ibrown@awsairbar.com](mailto:ibrown@awsairbar.com)  
**Accounting:** Melanie Thompson [admin@awsairbar.com](mailto:admin@awsairbar.com)

Parts Order Information:

To best fulfill your parts requirements, Gather the following information before contacting us:

- Header Make / Model
- AWS Fan SN (location shown in picture)

If you have any questions regarding the suitability of the parts you receive, please call the above number ASAP so that we can assist in ensuring the parts are correct and used properly.

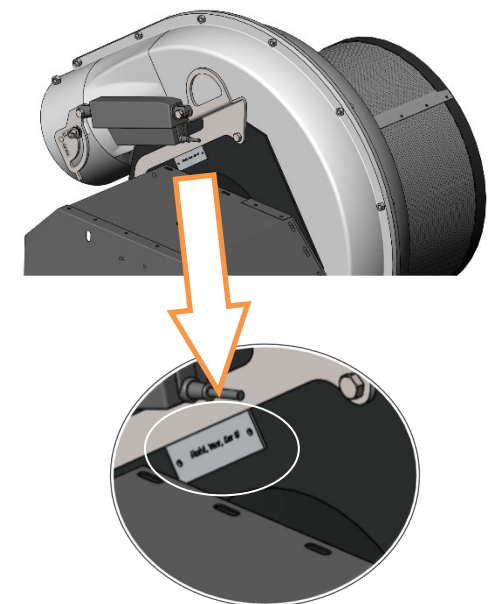

Fan Serial Number Location

The serial number plate for the fan is located on the fan mounting plate, below the throttle actuator mounting bracket.

Drive Identification

AWS uses 3 different secondary belt drive ratios depending on combine model; parts in this book are referenced as "A", "B" or "C" Drive for simplification. There are 2 methods of identifying the drive ratio:

1. Via the serial number (Either the 4<sup>th</sup> or 6<sup>th</sup> digit of the SN will be A,B or C)
2. Via combine manufacturer:  
A Drive - John Deere, Case IH (Max 550 rpm Input)  
B Drive - Gleaner, New Holland, Cat (550-600 rpm Input)  
C Drive - Claas (600-720 rpm Input)

Terms and Conditions:

1. All goods are F.O.B Mitchell, Ontario, Canada or Minot, ND USA
2. All Parts include 30 day warranty of defects.
3. Please indicate preferred shipment method with order (due to our shipping volume it is typically most cost effective to have parts shipped out prepaid, with shipping costs shown on the parts invoice).
4. Returns accepted within 12 months of purchase, must be unused and are subject to a 10% handling fee. They must be shipped back to AWS prepaid with prior authorization.

# Table of Contents

## All Models:

Blower Assembly.....	5
Rotary Screen Assembly.....	6
Feeder Tube Assembly.....	7
Rear Supply Assembly (Left Hand).....	8
Elbow Assembly (Left Hand).....	9
End Cap Assembly.....	10
Throttle Controls (Right Hand).....	11
Coupler (Right Hand).....	12
Rear Supply Assembly (Right Hand).....	13
Elbow Assembly (Right Hand).....	14
End Cap Assembly (Left Hand).....	15
Center Pivot (Pre-2015).....	16
Center Pivot (Post-2015).....	17
Manifold/Nozzles.....	18
Cable Kit.....	19

## John Deere:

STS Chassis Assembly.....	20
STS Drive Components.....	21
JD Walker Chassis Assembly.....	22
9000/10 Series Chassis Assembly.....	23
Drive Components.....	24
Fan Shaft Assemblies.....	25
600F Mount Arms.....	26
635D and 635FD Mount Arms.....	27
640FD Mount Arms (Pre-2015).....	28
640FD Mount Arms (Post-2015).....	29
900 Mount Arms(Right & Left).....	30

## Case/NH:

Case Chassis Assembly (Primary).....	31
Case Chassis Assembly (Secondary).....	32
Case 66 Drive Components.....	33
Case 88 Drive Components.....	34
Case 1020 Mount Arms.....	35
Case 2020/ NH 74C and 973 Mount Arms.....	36
Case 3020/ NH 740CF Mount Arms.....	37
MacDon FD75 Mount Arms.....	38
MacDon FD70 Mount Arms.....	39
New Holland Chassis Assembly.....	40
New Holland Drive Components.....	41

# Combine Mount Fan Components



## John Deere Combine Mounts

See pages 16-22 for parts index.

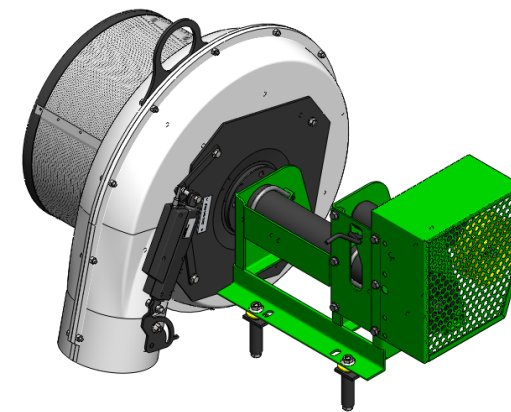

JD STS Combine Mount Assembly

### STS Blower Assembly:

John Deere S series combines	
John Deere 95/96/97/98 STS series combines	
Chassis Assembly	P.20
Drive; Small Rotor	P.21
Drive; Large Rotor	P.21

### 50/60 Walker Series Blower Assembly:

John Deere 9550/9650 WTS series combines	
Chassis Assembly	P.22
Drive Assembly	P.24

### 9000/10 Series Blower Assembly:

John Deere 9000/10 series combines	
Chassis Assembly	P.23
Drive Assembly	P.24

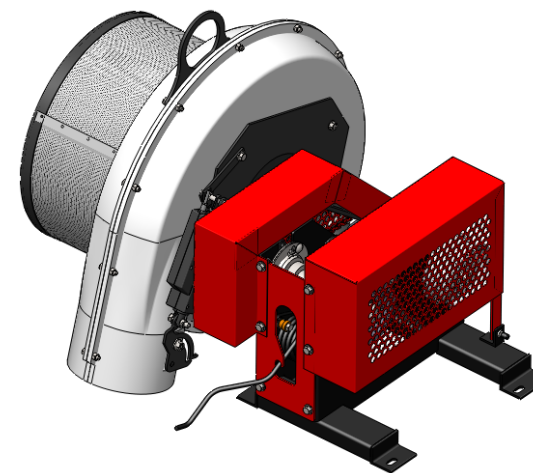

Case Combine Mount Assembly

## CASE/NH Combine Mounts

See Pages 23-28 for parts index.

### CASE/NH Blower Assembly include:

Case 1660	
Chassis Assembly	P.31-32
Case Drive Assembly	P.33-34

### NH Fixed Speed Assembly

Chassis Assembly	P.40
Drive Assembly	P.41

### NH Variable Speed Assembly (INSIDE MOUNT) :

NH 970 9070 7090	
Chassis Assembly	P. 40
Drive Assembly	P. 41

### NH Variable Speed Assembly (OUTSIDE MOUNT) :

NH 940 960 9040 9060 6090	
Chassis Assembly	P.40
Drive Assembly	P.41



NH Fixed Speed Combine Mount



# Blower Assembly

(Right Hand Combine Mount Shown)

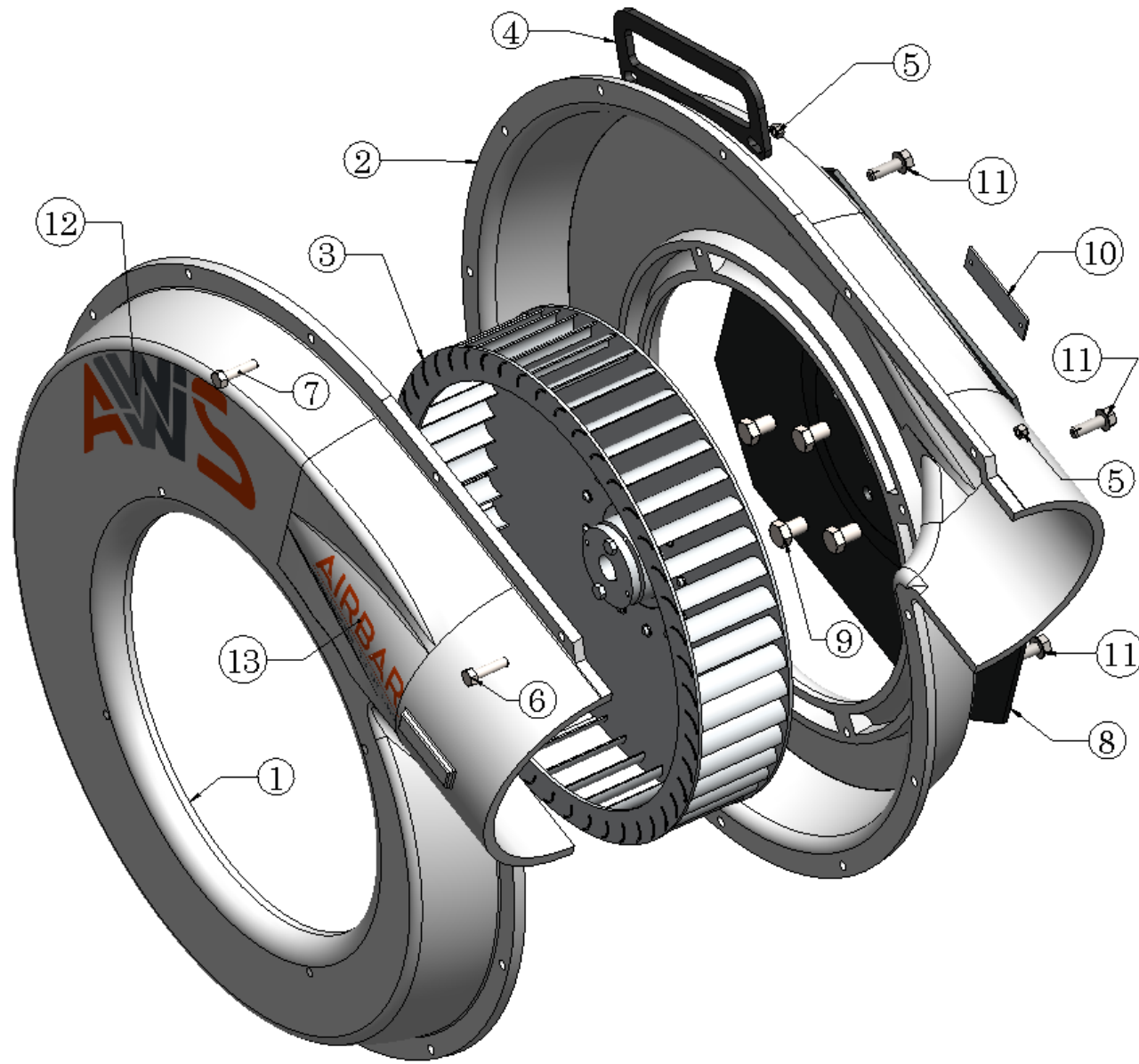

Ref.	Part Number	Description	Qty.
1	AWS0069	Fan Housing, RH	1
2	AWS0068	Fan Housing, LH	1
3	AWS0071	Impeller, Right Hand	1
4	AWS0157	Lift Hook	1
5		Nylock Nut, 5/16"	
6		Bolt, 5/16" x 1 1/4"	
7		Bolt, 5/16" x 1 1/2"	

Ref.	Part Number	Description	Qty.
8	AWS0067	Fan Plate	1
9		Bolt, 1/2 x 3/4"	4
10	AWS0065	Serial Number Plate	1
11		3/8 "x1" Self Tapping Bolt (4 manual, 2 electric)	4
12	AWS0783	AWS RH Fan Decal	1
13	AWS0784	Airbar Fan Decal	1

# Rotary Screen Assembly

For all Models

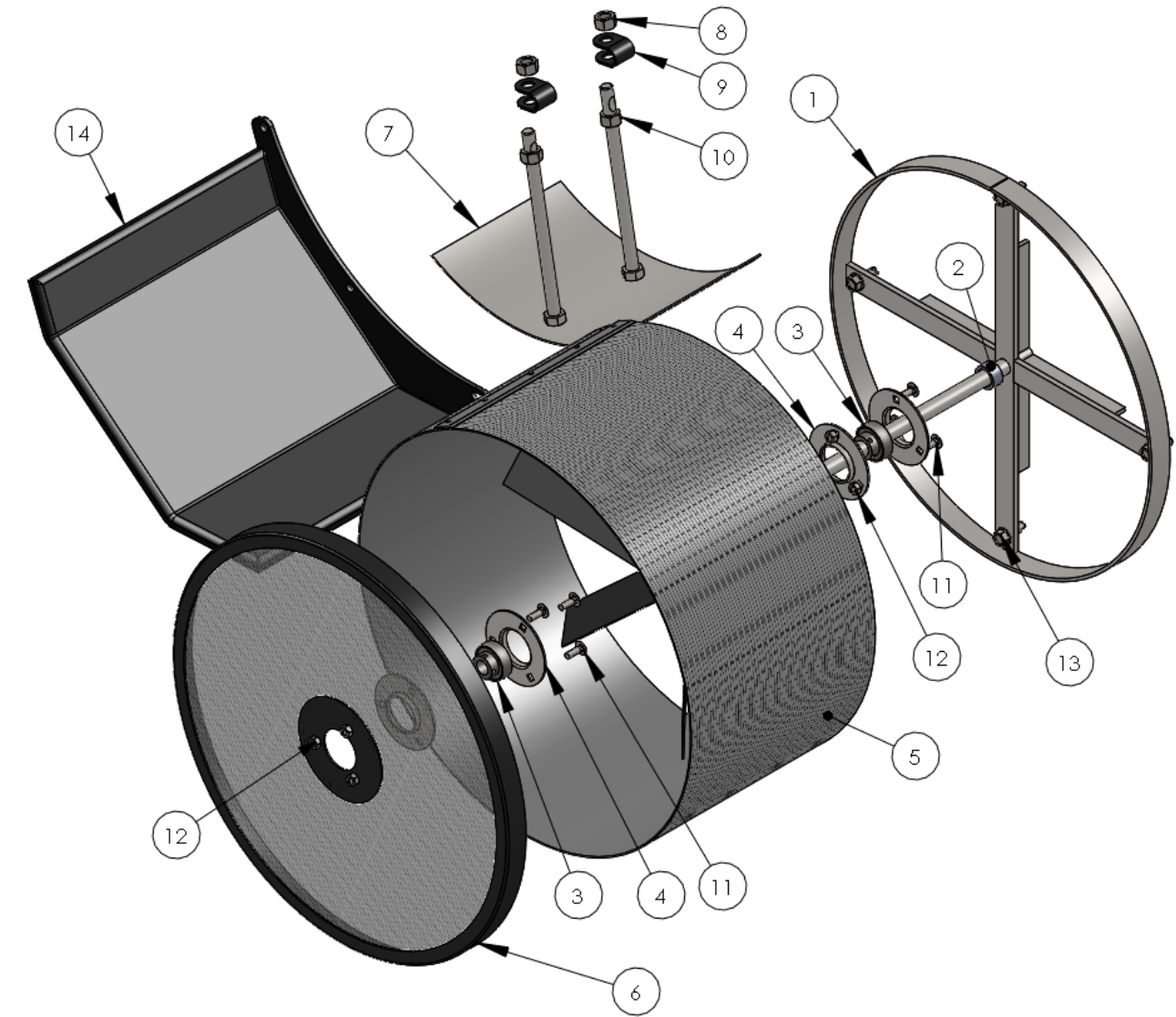

Ref.	Part Number	Description	Qty.	Ref.	Part Number	Description	Qty.
1	AWS0076	Rotary Screen Support	1	8		1/2" NC Stover Nut	
2	AWS0384	Spacer, Rotary Screen	1	9	AWS0082	Clevis	2
3	AWS0078	Bearing, Rotary Screen AS202-101	2	10		1/2" NC Jam Nut	
4	AWS0079	Bearing Flange, PF203	4	11		1/4" NC x 3/4" Carriage Bolt	6
5	AWS0077	Rotary Screen	1	12		1/4" NC Nylock Nut	6
6	AWS0080	Rotary Screen Cap	1	13		3/8" NC x 1" Flange Hex Self Tapping Bolt	4
7	AWS0081	Rotary Screen Cleanout	1	14	AWS0143	Rotary Screen Fender	1

**AWS0230 - Rotary Screen Assembly** Note: There is a Rotary Screen Assembly for Right and Left Hand Fans.

# Feeder Tube Assembly

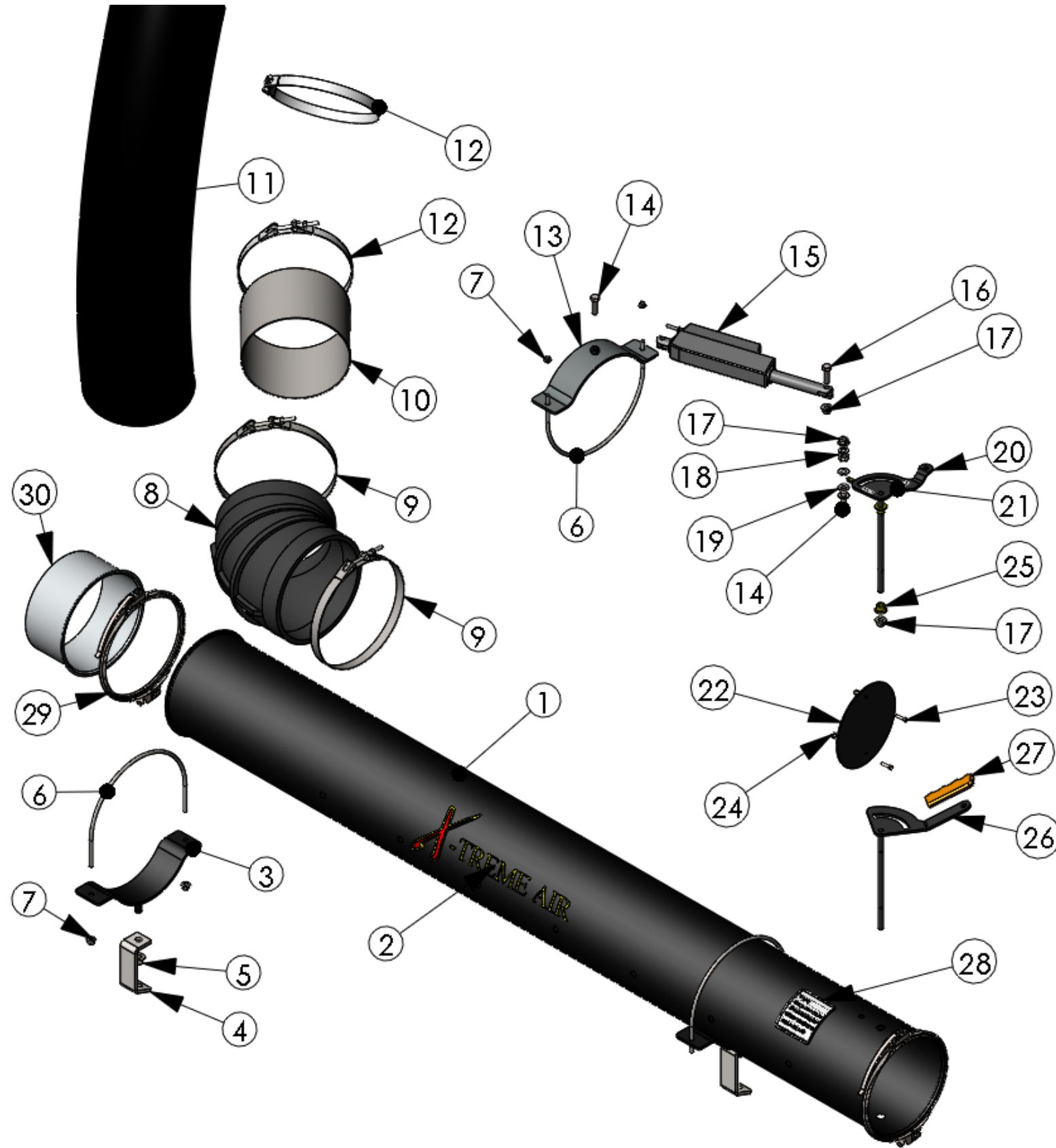

Item #	Part #	Description	Qty.	Item #	Part #	Description	Qty.
1	AWS0149	1 Flange Feeder Tube		16	AWS0514	$\frac{3}{8}$ " x $1\frac{1}{2}$ " Actuator Mount Bolt	
	AWS0257	2 Flange Feeder Tube		17		$\frac{3}{8}$ " NC Nylock Nut	
2	AWS0340	X-treme Air Decal		18	AWS0170	Spring Washers	
3	AWS0153	Saddle w/ Stud		19		$\frac{3}{8}$ " Flat Washer	
4	AWS0396	Angled Feeder Tube Support		20	AWS0214	LH Electric Throttle Shaft	
5		$\frac{1}{2}$ " NC Stover Nut		21	AWS0075	Open/Close Decal	
6	AWS0163	$\frac{1}{4}$ " NC x 8" Stainless Steel U-Bolt		22	AWS0114	Throttle Plate	
7		$\frac{1}{4}$ " NC Nylock Nut		23		10-32 x $\frac{3}{4}$ " Socket Head Screw	
8	AWS0091	90"x8" Elbow		24		10-32 Lock Nut	
9	AWS0086	8.75" Hose Clamp		25	AWS0512	Bronze Bushing	
10	AWS0160	Connector Pipe		26	AWS0074	LH Throttle Shaft Lever	
11	AWS0410	8"x60" Flex Hose (Pre-Cut)		27	AWS0141	Grip	
12	AWS0085	8.25" Hose Clamp		28	AWS0323	Baffle Notice Decal	
13	AWS0283	Actuator Saddle		29	AWS0151	Q.R. Clamp	
14		$\frac{3}{8}$ " NC x $1\frac{1}{2}$ " Bolt		30	AWS0152	Short Coupler	
15	AWS0095	Throttle Control Actuator					

# Rear Supply Assembly (Left Hand)

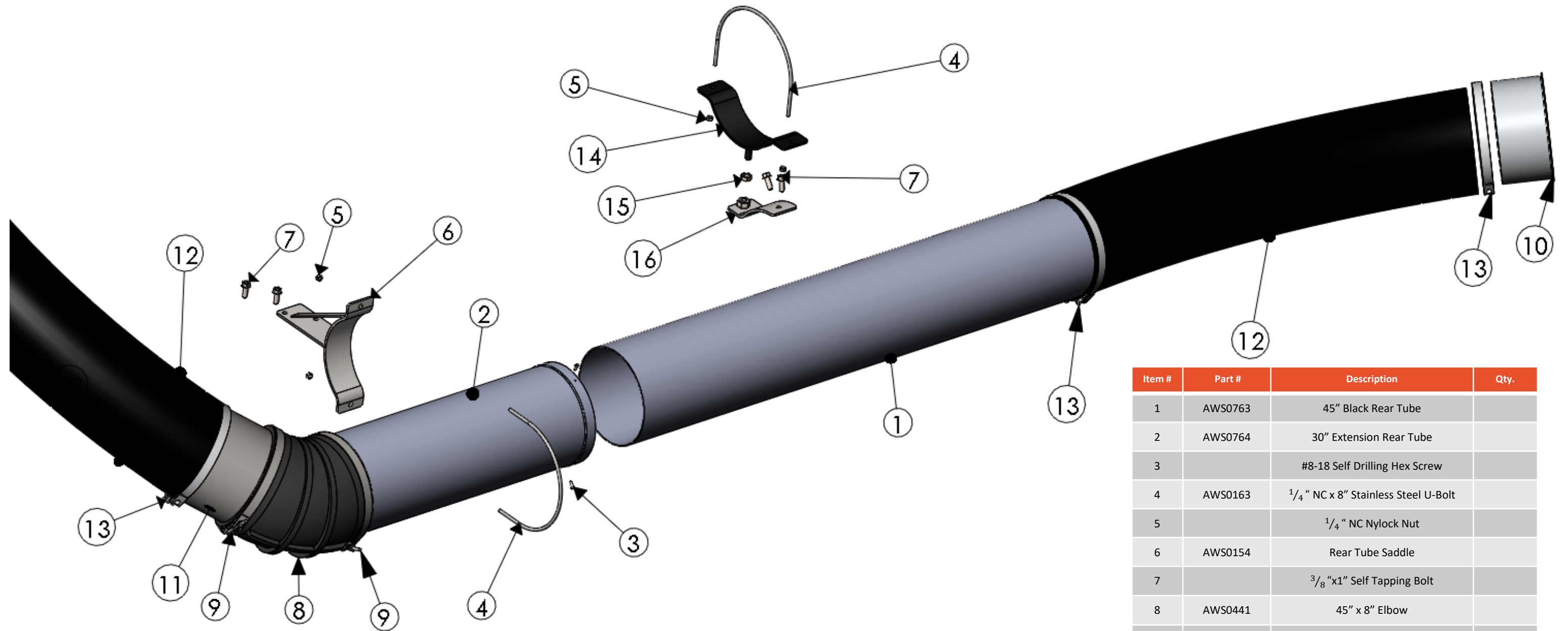

Item #	Part #	Description	Qty.
1	AWS0763	45" Black Rear Tube	
2	AWS0764	30" Extension Rear Tube	
3		#8-18 Self Drilling Hex Screw	
4	AWS0163	1/4" NC x 8" Stainless Steel U-Bolt	
5		1/4" NC Nylock Nut	
6	AWS0154	Rear Tube Saddle	
7		3/8" x1" Self Tapping Bolt	
8	AWS0441	45" x 8" Elbow	
9	AWS0086	8.75" Hose Clamp	
10	AWS0152	Short Coupler	
11	AWS0160	Connector Pipe	
12	AWS0410	8" x 60" Flex Hose (Pre-Cut)	
13	AWS0085	8.25" Hose Clamp	
14	AWS0153	Saddle w/ Stud	
15		1/2" NC Jam Nut	
16	AWS0644	Rear Tube Round Saddle Bracket	



# Elbow Assembly (Left Hand)

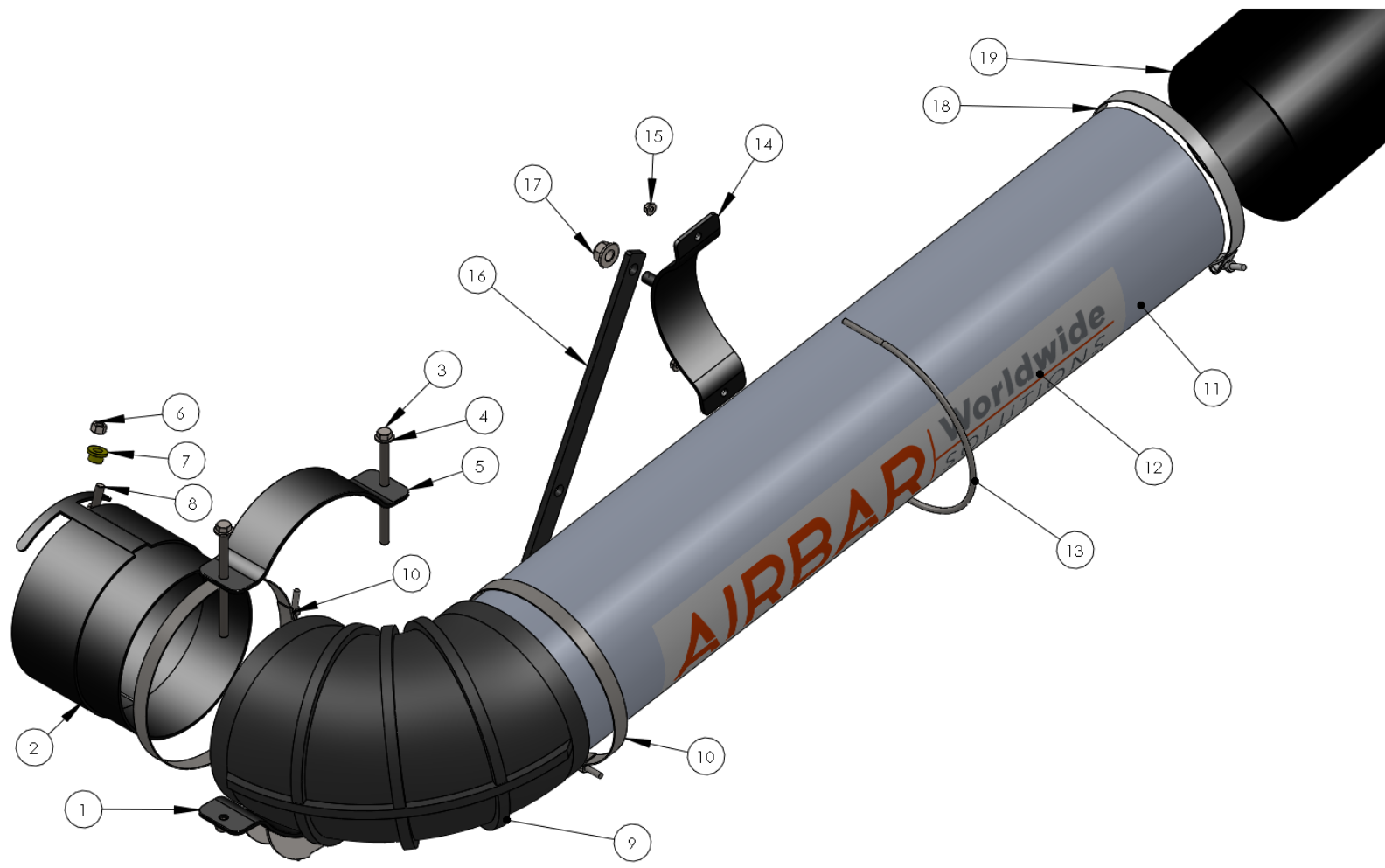

Item #	Part #	Description	Qty.
1	AWS0102	Manifold Arm	
2	AWS0092	Lock Sleeve	
3	AWS0161	3/8" NC x 5 1/2" Gr. 8 Bolt	
4		3/8" Flat Washer	
5	AWS0123	Saddle Clamp	
6		3/8" NC Nylock Nut	
7	AWS0512	Bronze Bushing	
8		3/8" NC x 1" Bolt	
9	AWS0091	90 x 8" Elbow	
10	AWS0086	8.75" Hose Clamp	

Item #	Part #	Description	Qty.
11	AWS0087	40" Transition Tube	
12	AWS0782	AWS Logo 24" x 4" Decal	
13	AWS0163	1/4" NC x 8" Stainless Steel U-Bolt	
14	AWS0153	Saddle w/ Stud	
15		1/4" NC Nylock Nut	
16	AWS0090	Transition Tube Support	
17		1/2" NC Nylock Nut	
18	AWS0085	8.25" Hose Clamp	
19	AWS0410	8" x 60" Flex Hose (Pre-Cut)	

# End Cap Assembly (Left Hand)



Item #	Part #	Description	Qty.
1	AWS0102	Manifold Arm	
2	AWS0123	Saddle Clamp	
3	AWS0479	4" End Cap Spacer	
4		3/8" Flat Washer	
5		3/8" NC x 5" Bolt	
6	AWS0810	End Cap Base	
7	AWS0811	End Cap Lever	
8	AWS0813	6 Bolt End Cap Plate	
9		1/4" NC Flange Nut	

Item #	Part #	Description	Qty.
10		#8-18 Self Drilling Hex Screw	
11		3/8" NC x 3" Bolt	
12		3/8" NC Nylock Nut	
13	AWS0103	Actuator Pivot	
14		3/8" NC x 3/4" Bolt	
15	AWS0546	LA23 Split Reel Actuator	
16	AWS0514	3/8" x 1 1/2" Actuator Mount Bolt	
17	AWS0814	/ LeverEnd Cap Assembly w/	

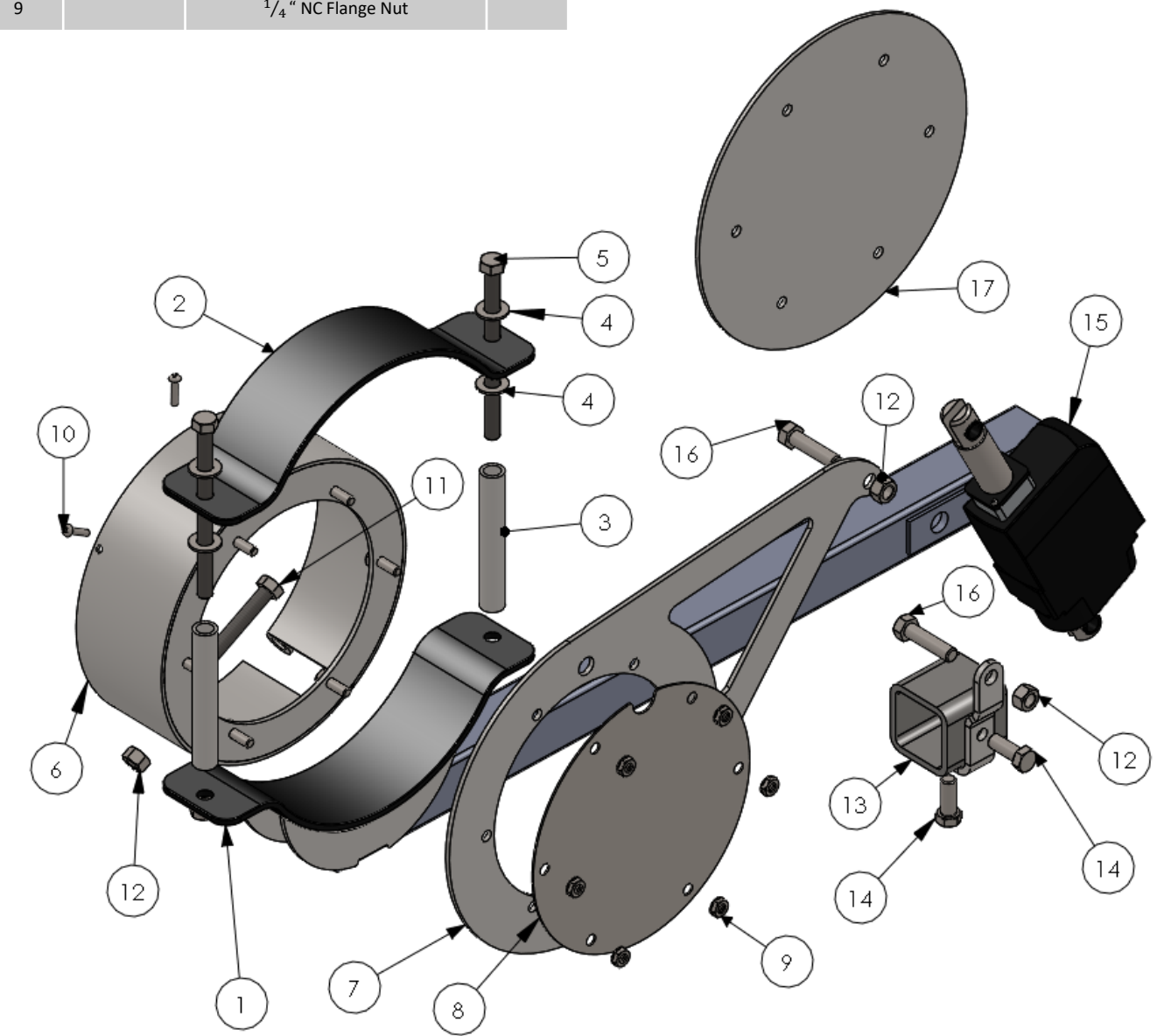

# Throttle Controls (Right Hand)

There are four different throttle control arrangements used to regulate the air flow. These can be either manually controlled or electric actuator controlled. Combine mount systems routed to the left feature this control valve inside the feeder house tube, while right hand delivery are fan mounted. See next page for left-routed combine mount controls.

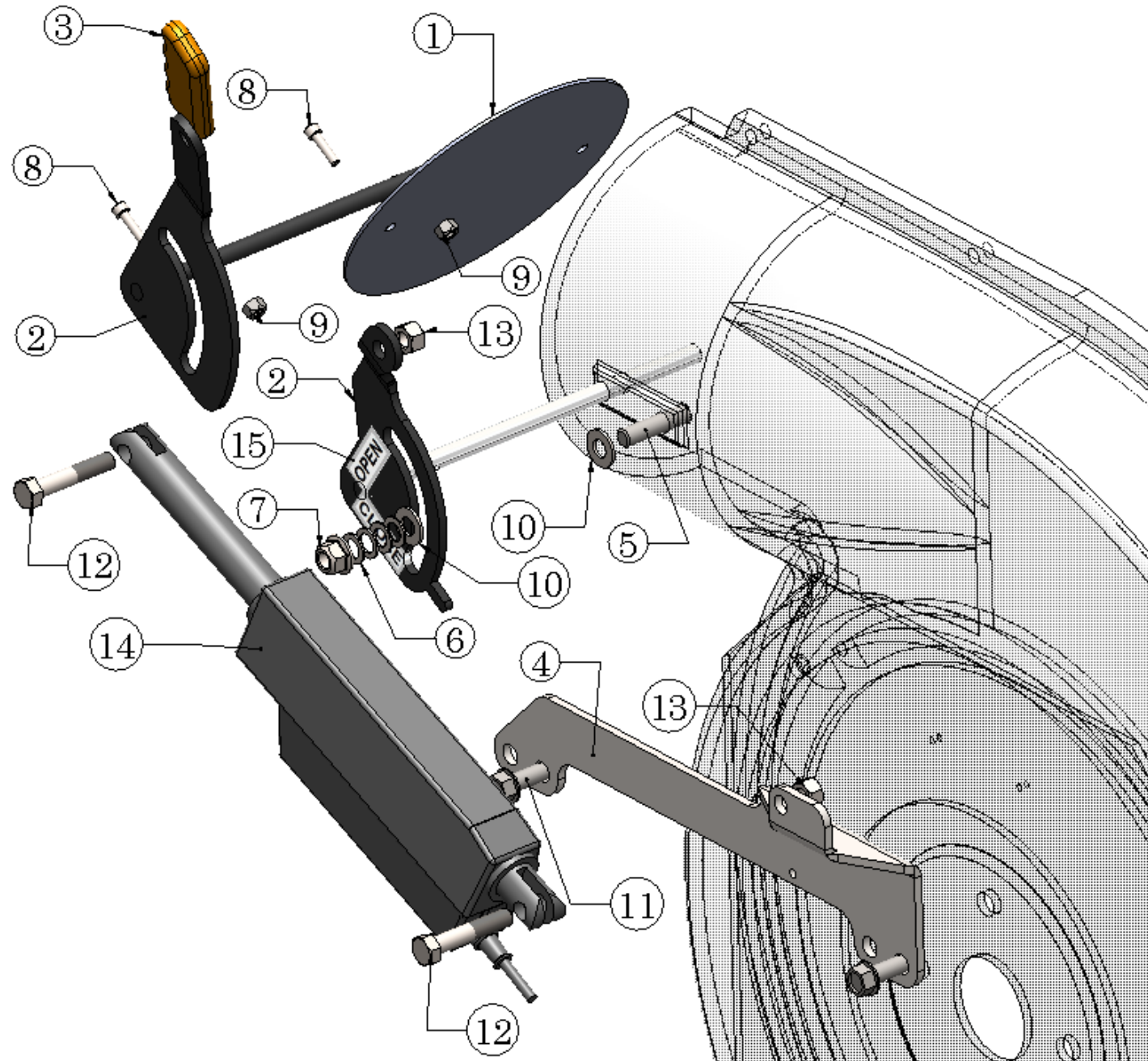

(Right Hand Shown)

Item #	Part #	Description	Qty.
1	AWS0114	Throttle Plate	1
2	AWS0212	Throttle Shaft, RH (Electric)	1
	AWS0173	Throttle Control RH (Manual)	1
3	AWS0141	Grip	1
4	AWS0203	Actuator Mount	1
5	AWS0171	M10 x 30 Stud	1
6	AWS0170	$\frac{3}{8}$ " Spring Washers	4
7		M10-1.5 Flange Nylon Locknut	1
8		10-23 x $\frac{3}{4}$ " Socket HD. Cap Screw	2
9		#10-32 SS Nylock Nut	2
10		$\frac{3}{8}$ " Flat Washer	4
11		$\frac{3}{8}$ " NC $1\frac{3}{4}$ " Hex Bolt	2
12	AWS0514	Actuator Bolt	2
13		10-23 x $\frac{3}{4}$ " Socket HD. Cap Screw	1
14	AWS0095	Actuator, LA12	1
15	AWS0075	Decal, OPEN CLOSE	1

# Coupler (Right Hand)

Item #	Part #	Description	Qty.
1	AWS0152	Short Coupler	
2	AWS0151	Q.R. Clamp	
3	AWS0410	8" x 60" Flex Hose (Pre-Cut)	
4	AWS0085	8.25" Hose Clamp	
5	AWS0637	Q.R. Storage Base	
6		$\frac{3}{8}$ " NC x 1" Bolt	
7		$\frac{3}{8}$ " NC Nylock Nut	

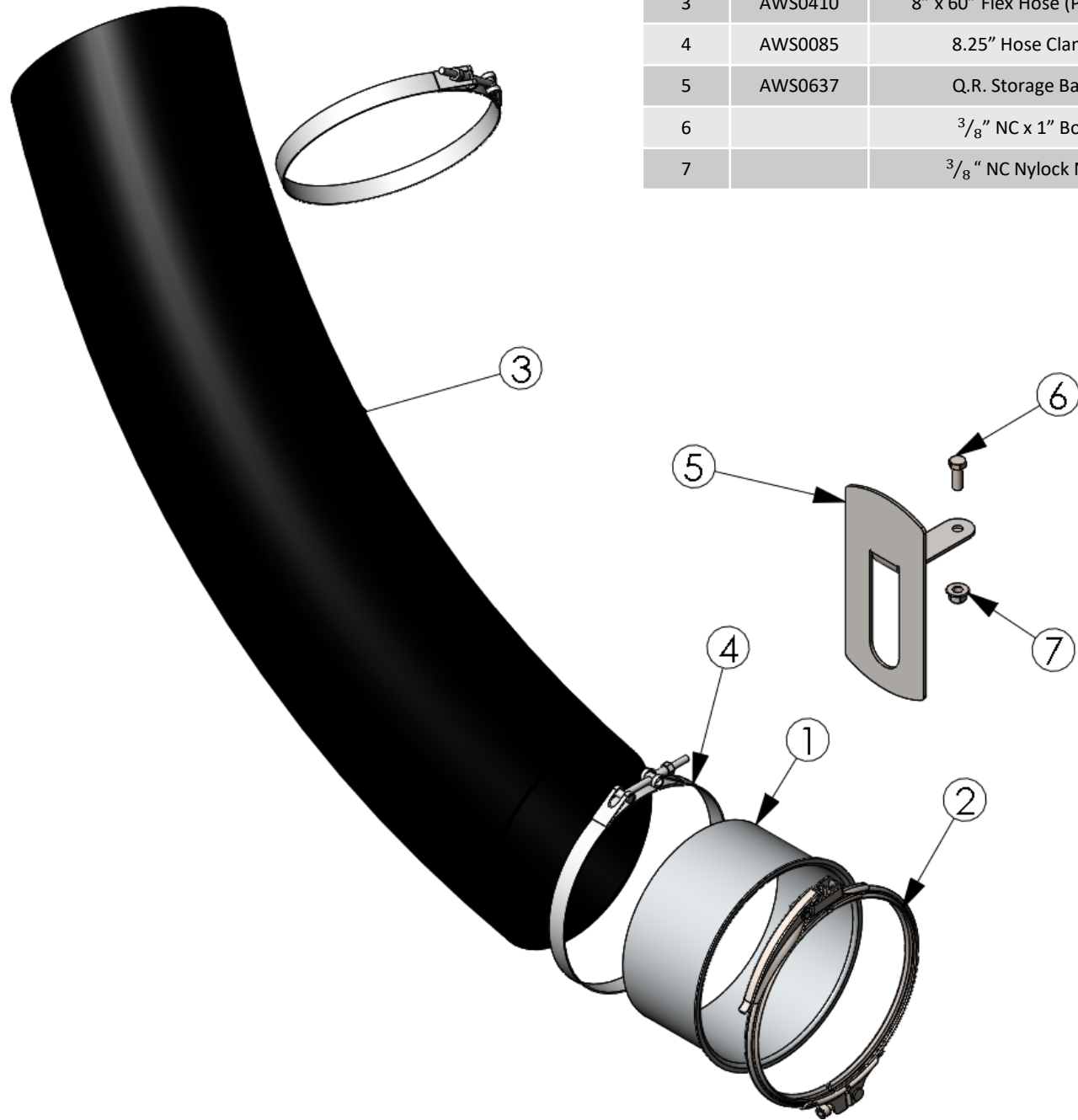

# Rear Supply Assembly (Right Hand)

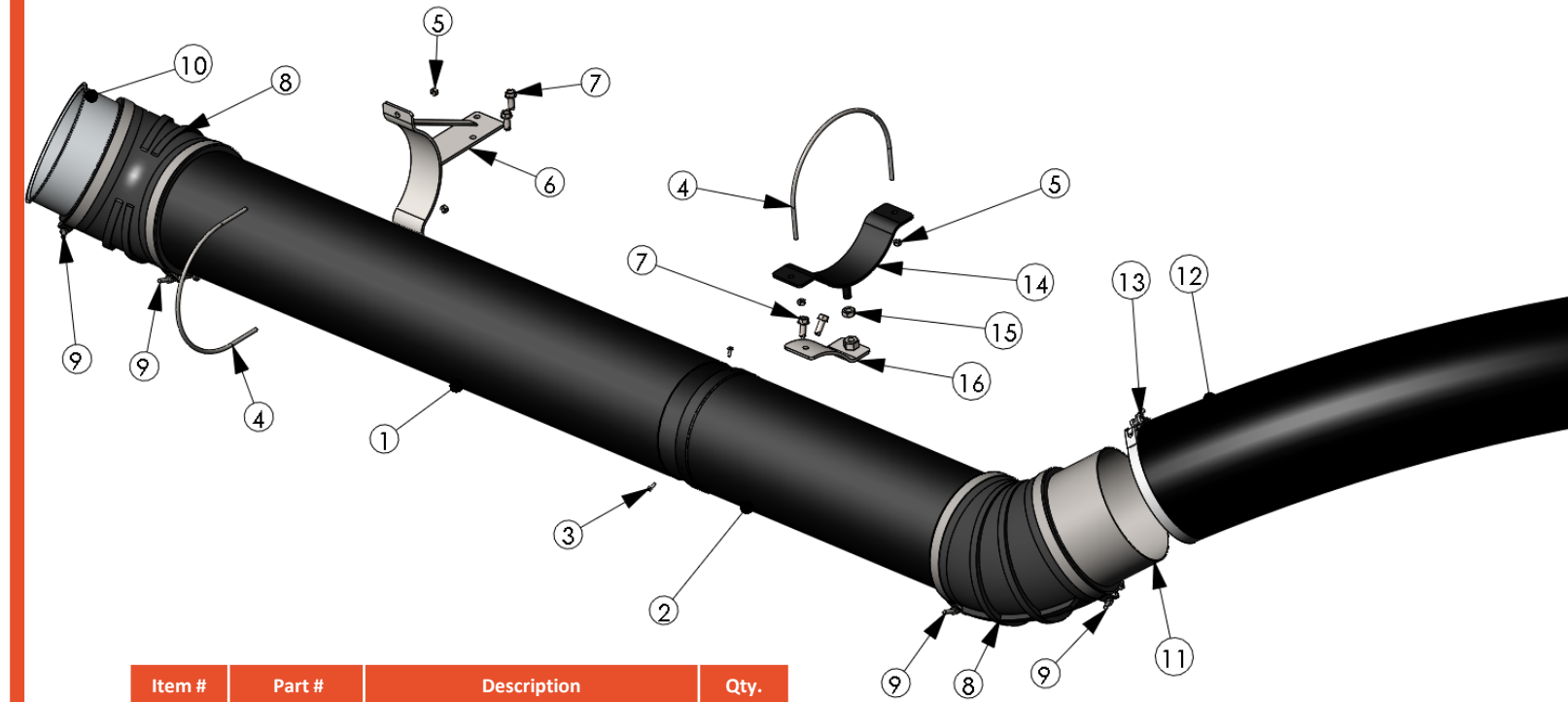

Item #	Part #	Description	Qty.
1	AWS0763	45" Black Rear Tube	
2	AWS0764	30" Rear Tube Extension	
3			
4	AWS0163	$\frac{1}{4}$ " NC x 8" Stainless Steel U-Bolt	
5			
6	AWS0154	Rear Tube Saddle	
7		$\frac{3}{8}$ " x 1" Self Tapping Bolt	
8	AWS0441	45 x 8" Elbow	
9	AWS0086	8.75" Hose Clamp	
10	AWS0152	Short Coupler	
11	AWS0160	Connector Pipe	
12	AWS0410	8" x 60" Flex Hose (Pre-Cut)	
13	AWS0085	8.25" Hose Clamp	
14	AWS0153	Saddle w/ Stud	
15		$\frac{1}{2}$ " NC Jam Nut	
16	AWS0644	Rear Tube Saddle Bracket (Round)	



# Elbow Assembly (Right Hand)

# End Cap Assembly (Left Hand)



Item #	Part #	Description	Qty.
1	AWS0102	Manifold Arm	
2	AWS0123	Saddle Clamp	
3	AWS0479	4" End Cap Spacer	
4		3/8" Flat Washer	
5		3/8" NC x 5 1/2" Gr. 8 Bolt	
6	AWS0810	End Cap Base	
7	AWS0811	End Cap Lever	

Item #	Part #	Description	Qty.
8	AWS0813	6 Bolt End Cap Plate	
9		1/4" NC Flange Nut	
10		#8-18 Self Drilling Hex Screw	
11		3/8" NC x 3" Bolt	
12		3/8" NC Nylock Nut	
13	AWS0103	Actuator Pivot	
14		3/8" NC x 3/4" Bolt	
15	AWS0546	LA23 Split Reel Actuator	
16		3/8" x 1 1/2" Actuator Mount Bolt	
17	AWS0814	End Cap Assembly w/ Lever	

Item #	Part #	Description	Qty.
1	AWS0102	Manifold Arm	
2	AWS0123	Saddle Clamp	
3		3/8" Flat Washer	
4		3/8" NC x 5 1/2" Gr. 8 Bolt	
5	AWS0092	Lock Sleeve	
6		3/8" NC Nylock Nut	
7	AWS0512	Bronze Bushing	
8		3/8"x1" Bolt	
9	AWS0091	90 x 8" Elbow	
10	AWS0086	8.75" Hose Clamp	
11	AWS0441	45 x 8" Elbow	
12	AWS0481	8" Black Connector Pipe	

Item #	Part #	Description	Qty.
13	AWS0087	40" Transition Tube	
14	AWS0782	24" x 4" AWS Logo Decal	
15	AWS0163	1/4" NC x 8" Stainless Steel U-Bolt	
16	AWS0153	Saddle w/ Stud	
17		1/4" NC Flange Nut	
18	AWS0090	Transition Tube Support	
19		1/2" NC Nylock Nut	
20	AWS0085	8.25" Hose Clamp	
21	AWS0410	8" x 60" Flex Hose (Pre-Cut)	

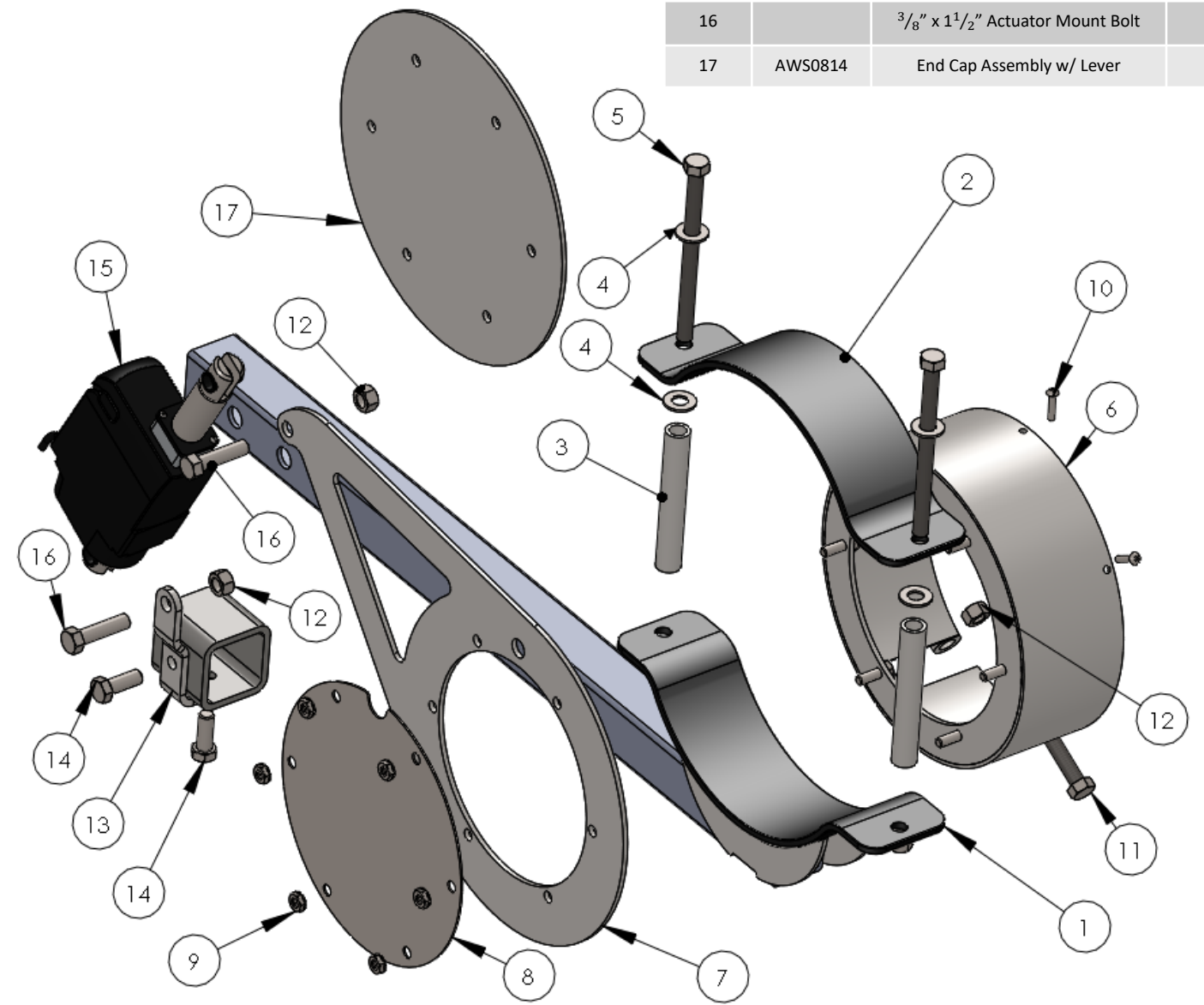

# Center Pivot (Pre-2015)

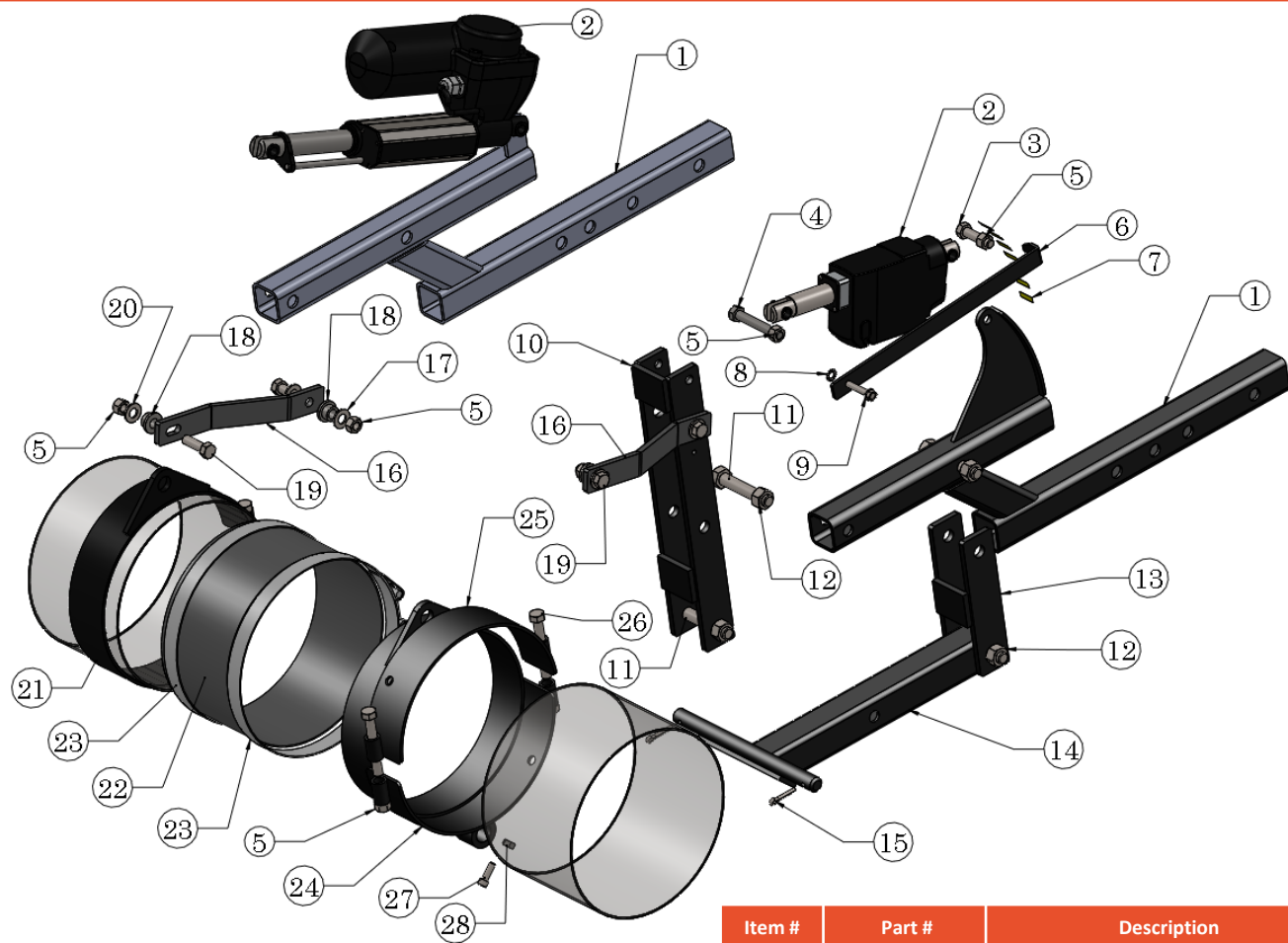

Item #	Part #	Description	Qty.
1	AWS0598	CP Tube	
2	AWS0191	Manifold Tilt Actuator	
	AWS0546	LA23 Split Reel Actuator	
3	AWS0514	3/8" x 1 1/2" Actuator Mount Bolt	
4		3/8" x 2 1/2" Actuator Mount Bolt	
5		3/8" NC Nylock Nut	
6	AWS0545	Manifold Tilt Indicator	
7	AWS0669	Actuator Indicator Decal	
8		1/4" External Tooth Lock Washer	
9		1/4" x 3/4" Carriage Bolt	
10	AWS0602	CP Front Link	
11		1/2" NC x 2 1/2" Bolt	
12		1/2" NC Nylock Nut	
13	AWS0603	CP Rear Link	

Item #	Part #	Description	Qty.
14	AWS0601	CP Lower Control Arm	
15		5/32" x 1" Cotter Pin	
16	AWS0605	CP Upper Link	
17		16mm Shim	
18	AWS0512	Bronze Bushing	
19		3/8" NC x 1" Bolt	
20		3/8" Flat Washer	
21	AWS0604	CP Clamp	
22	AWS0883	CP Hose	
23	AWS0085	8.25" Hose Clamp	
24	AWS0600	CP Saddle	
25	AWS0599	CP Top Saddle	
26		3/8" x 2 1/2" Bolt	
27		1/4" x 3/4" Socket Head Cap	
28		1/2" NC Nylock Nut	

# Center Pivot (Post-2015)

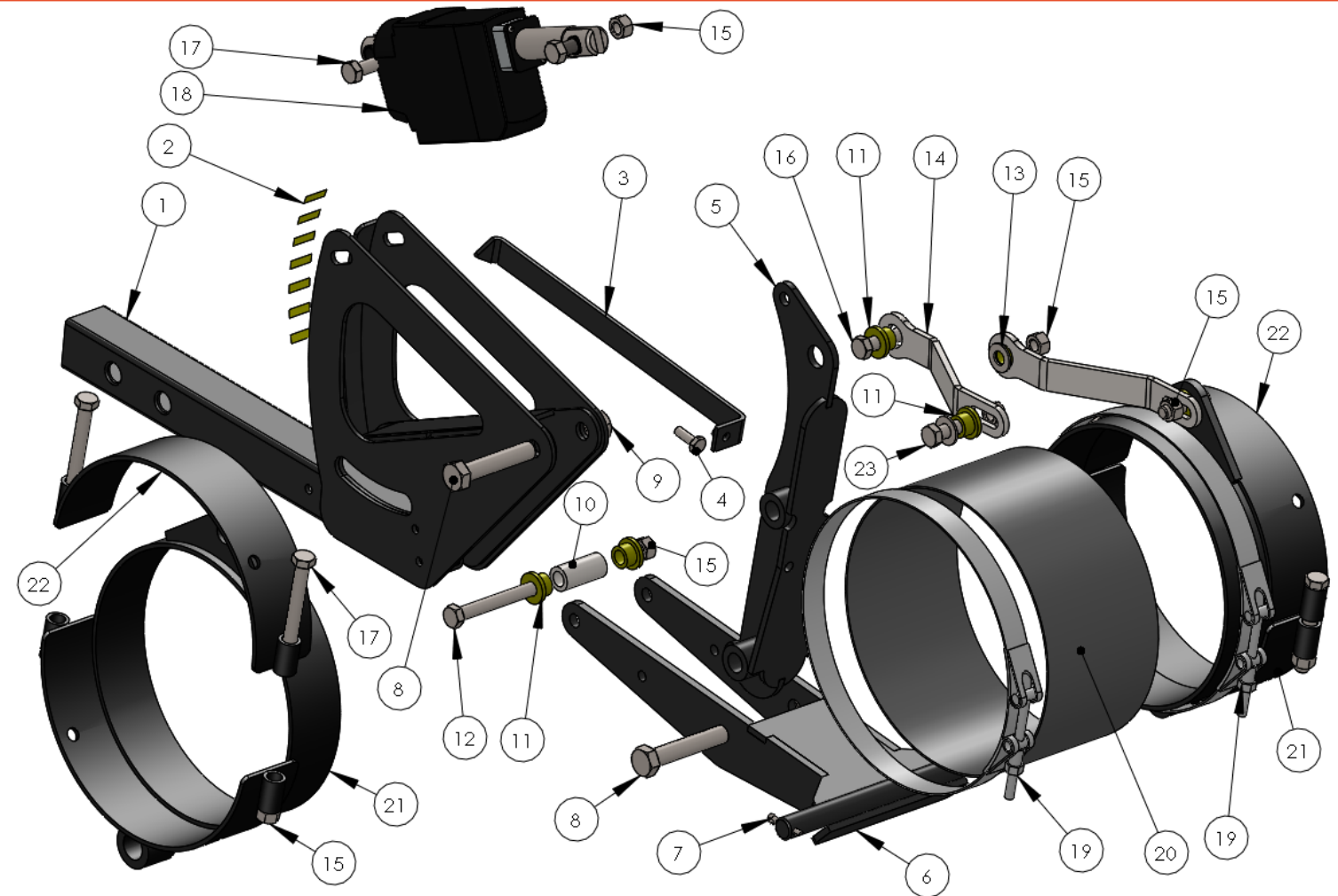

Item #	Part #	Description	Qty.
1	AWS0771	Manifold Arm, Center Base	
2	AWS0669	Actuator Indicator Decal	
3	AWS0775	Manifold Arm, Center Tilt Indicator	
4		1/4" x 3/4" Carriage Bolt	
5	AWS0772	Manifold Arm, Center Lever	
6	AWS0773	Manifold Arm, Center Cradle	
7		5/32" x 1" Cotter Pin	
8		1/2" NC x 3" Bolt	
9		1/4" x 3/4" Carriage Bolt	
10	AWS0776	Manifold Arm, Center Spacer 3/8" x 2"	
11	AWS0512	Bronze Bushing	
12		3/8" NC x 3" Bolt	

Item #	Part #	Description	Qty.
13		16mm Shim	
14	AWS0774	Manifold Arm, Center Link	
15		3/8" NC Nylock Nut	
16		3/8" NC x 2 1/2" Bolt	
17		3/8" x 1 1/2" Actuator Mount Bolt	
18	AWS0546	LA23 Split Reel Actuator	
19	AWS0085	8.25" Hose Clamp	
20	AWS0883	CP Hose	
21	AWS0600	CP Saddle	
22	AWS0599	CP Top Saddle	
23		3/8" x 1 1/4" Bolt	

# Manifold/Nozzles

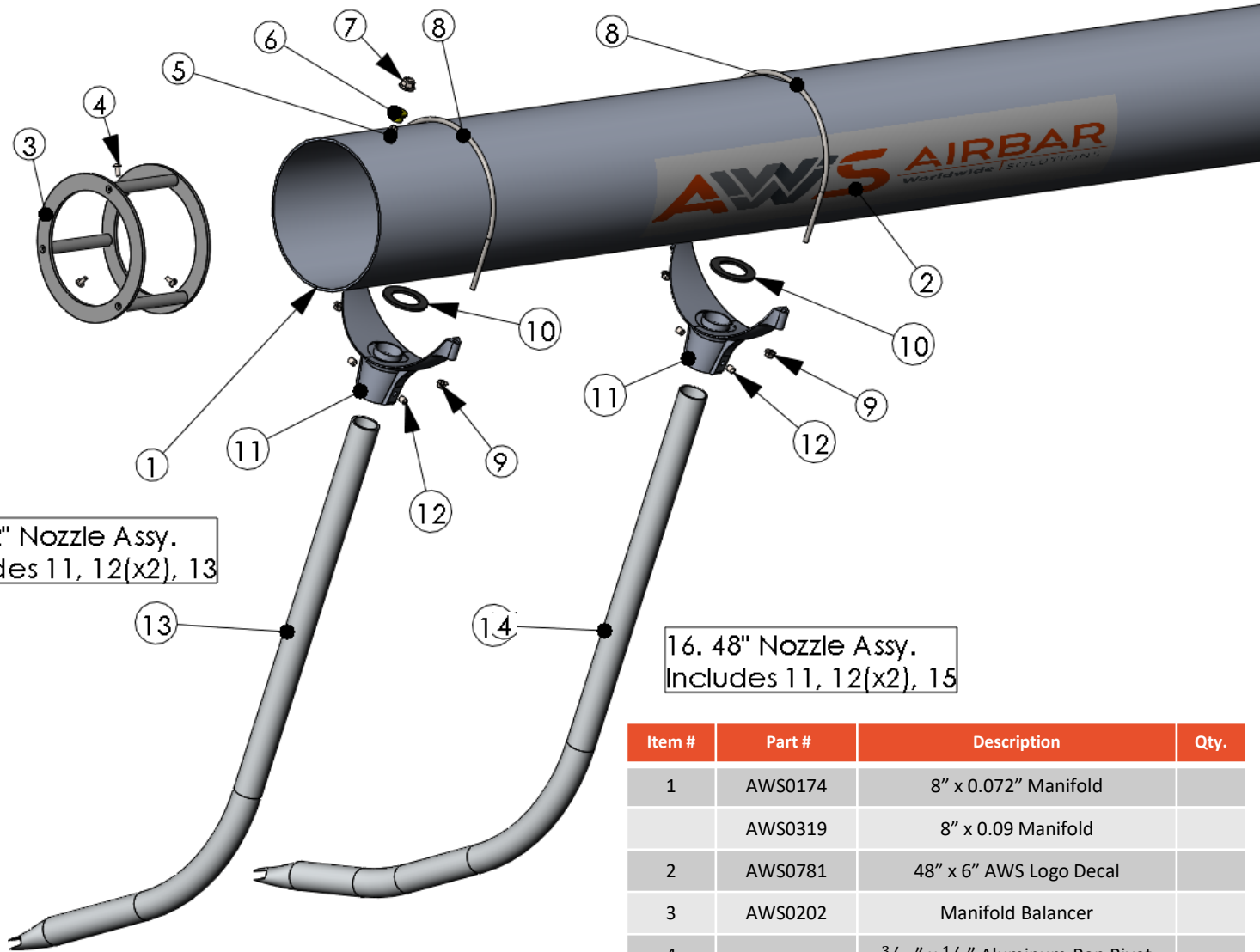

14. 42" Nozzle Assy.  
Includes 11, 12(x2), 13

16. 48" Nozzle Assy.  
Includes 11, 12(x2), 15

Item #	Part #	Description	Qty.
1	AWS0174	8" x 0.072" Manifold	
	AWS0319	8" x 0.09 Manifold	
2	AWS0781	48" x 6" AWS Logo Decal	
3	AWS0202	Manifold Balancer	
4		3/16" x 1/4" Aluminum Pop Rivet	
5		3/8" NC x 1" Bolt	
6	AWS0512	Bronze Bushing	
7		3/8" NC Nylock Nut	
8	AWS0163	1/4" NC x 8" Stainless Steel U-Bolt	
9		1/4" NC Nylock Nut	
10	AWS0116	Nozzle Gasket	
11	AWS0760	Nozzle Saddle	
12		M8 x 10 Stainless Set Screw	
13	AWS0762	42" Nozzle Tube	
14	AWS0766	48" Double Bend Nozzle Tube	

# Cable Kit

(LH Supply Shown)

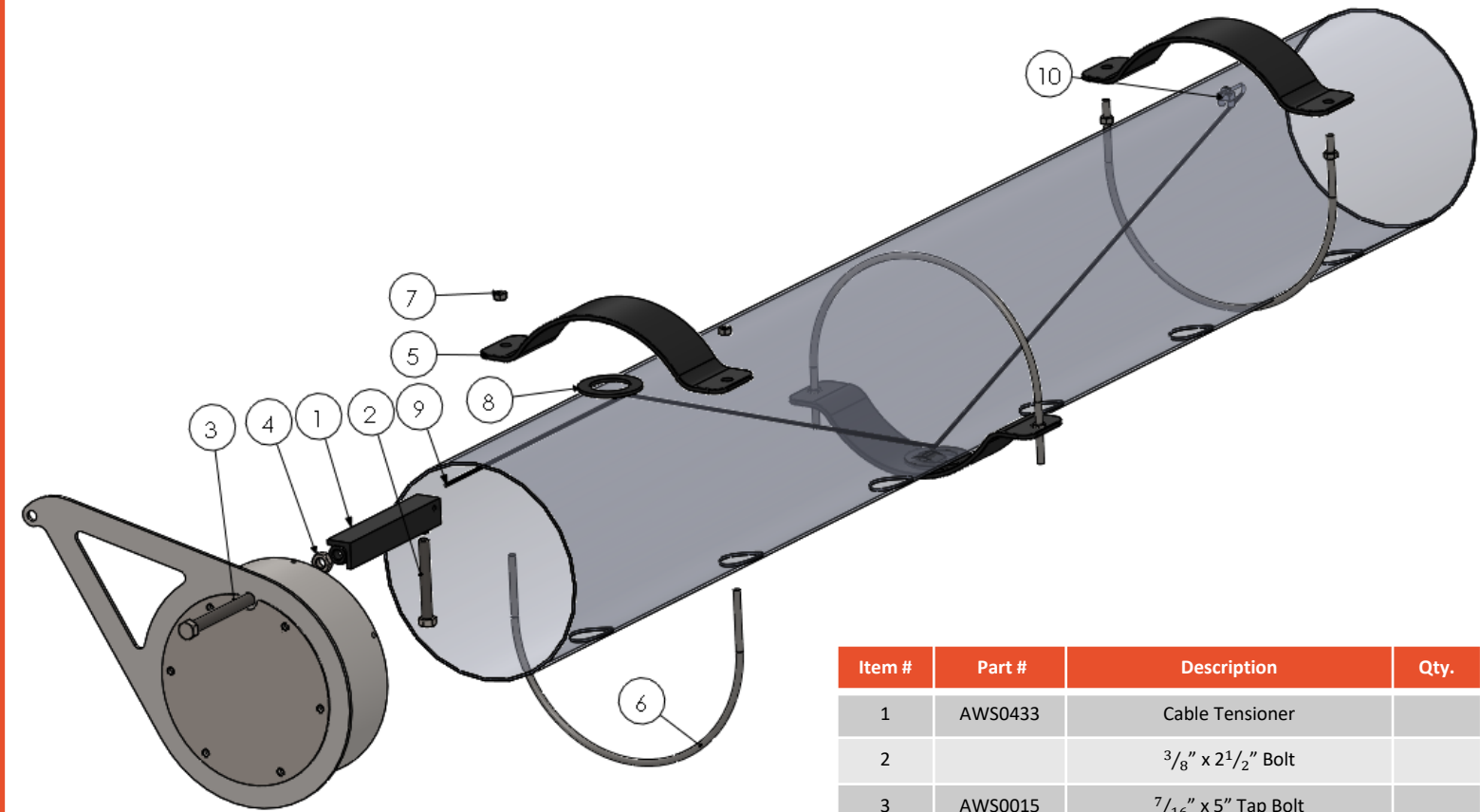

Item #	Part #	Description	Qty.
1	AWS0433	Cable Tensioner	
2		3/8" x 2 1/2" Bolt	
3	AWS0015	7/16" x 5" Tap Bolt	
4		7/16" Jam Nut	
5	AWS0435	Cable Anchor Saddle	
6	AWS0163	1/4" NC x 8" Stainless Steel U-Bolt	
7		1/4" NC Nylock Nut	
8	AWS0116	Nozzle Gasket	
9	AWS0427	1/8" Cable	
10	AWS0504	1/8" Cable Clamp	



# John Deere STS Combine Mount

(Chassis Assembly)

# STS Series Drive Components

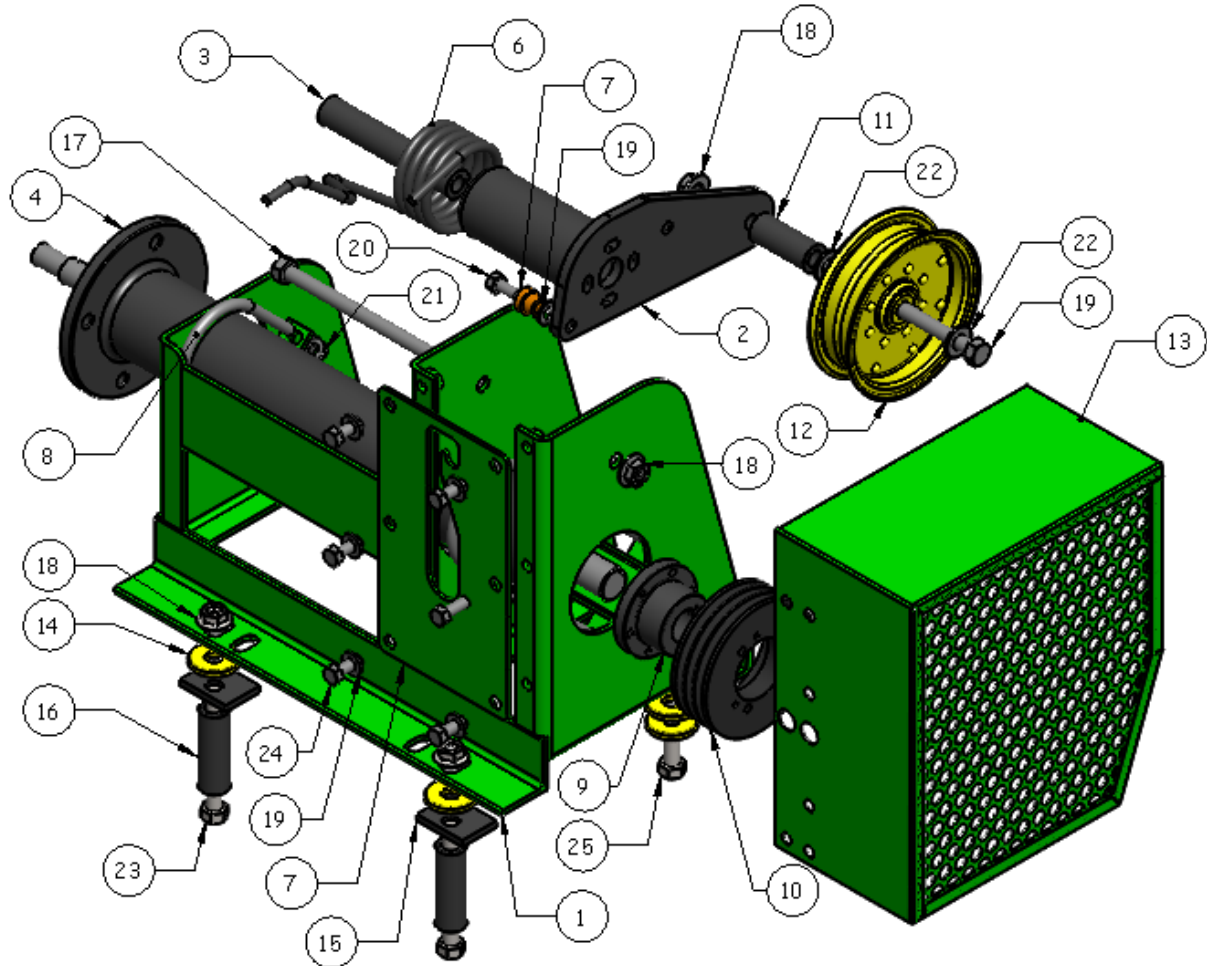

Item #	Part #	Description	Qty.
1	AWS0366	STS Chassis Assembly	1
2	AWS0261	Idler Arm (Torsion Type)	1
3	AWS0260	Idler Arm 5 <sup>5</sup> / <sub>8</sub> " Bushing	1
4	AWS0129	25" Fan Shaft Assembly	1
		(See Breakout on pg.24)	
5	AWS0512	Bushing	1
6	AWS0259	Torsional Spring	1
7	AWS0312	50 Series Chassis Center	1
8	AWS0039	3" Plated U-Bolt	3
9	AWS0033	SDS 1 <sup>1</sup> / <sub>8</sub> " Busing	1
10	AWS030	3VX 4.75-3 Sheave	1
11	AWS0112	1 <sup>1</sup> / <sub>2</sub> " x 2 <sup>3</sup> / <sub>8</sub> " Spacer	1
12	AWS0111	A Drive Idler (Combine)	1
13	AWS0333	50 Series Combine Sheild	1

Item #	Part #	Description	Qty.
14	AWS0233	1 <sup>1</sup> / <sub>2</sub> " x 1 <sup>5</sup> / <sub>8</sub> " - 1 <sup>1</sup> / <sub>4</sub> " Washer (95 Ser.)	14
15	AWS0234	Flat Side Washer	2
16	AWS0227	1 <sup>1</sup> / <sub>2</sub> " x 3" Spacer	2
	AWS0589	1 <sup>1</sup> / <sub>2</sub> " x 2 <sup>1</sup> / <sub>4</sub> " Spacer (S Series)	3
17		1 <sup>1</sup> / <sub>2</sub> " NC x 6 <sup>1</sup> / <sub>2</sub> " Bolt	1
18		1 <sup>1</sup> / <sub>2</sub> " Flanged Hex Nut	6
19		3 <sup>3</sup> / <sub>8</sub> " Flat Washer	6
20		3 <sup>3</sup> / <sub>8</sub> " NC x 7 <sup>7</sup> / <sub>8</sub> " Bolt	1
21		3 <sup>3</sup> / <sub>8</sub> " Flanged Hex Nut	6
22		1 <sup>1</sup> / <sub>2</sub> " Flat Washer	4+/-
23		1 <sup>1</sup> / <sub>2</sub> " NC x 4 <sup>1</sup> / <sub>2</sub> " Bolt	3
		1 <sup>1</sup> / <sub>2</sub> " NC x 3 <sup>1</sup> / <sub>2</sub> " Bolt (S Series)	3
24		3 <sup>3</sup> / <sub>8</sub> " NC x 1" Bolt	6
25		1 <sup>1</sup> / <sub>2</sub> " NC x 1 <sup>1</sup> / <sub>2</sub> " Bolt	2

**SMALL (9560 9570 S550):**

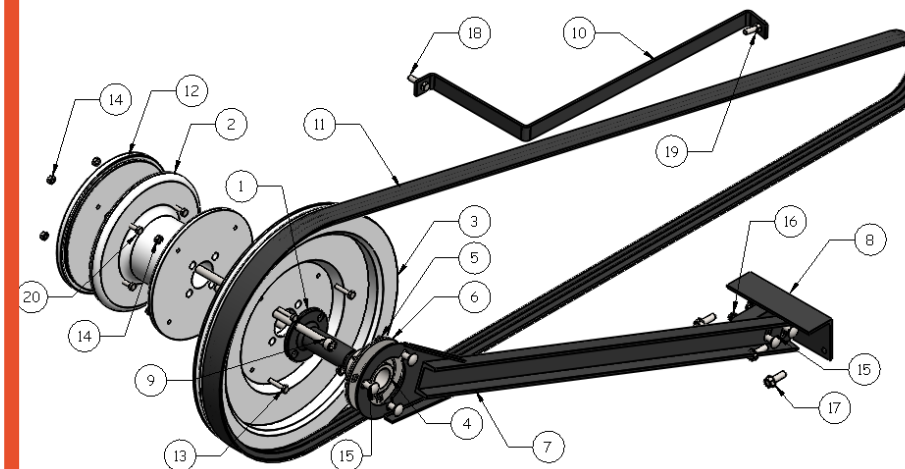

Item #	Part #	Description	Qty.
1	AWS0419	JD 9560 Axle	1
2	AWS0405	STS Spacer	1
3	AWS0408	STS Aluminum Sheave	1
4	AWS0003	1 <sup>3</sup> / <sub>8</sub> " Bearing	1
5	AWS0001	Bearing Flange (PF207)	1
6	AWS0420	Greasable Bearing Flange	1

Item #	Part #	Description	Qty.
7	AWS0418	STS9560 Torque Arm	1
8	AWS0417	STS9560 Torque Arm Bracket	1
	AWS0595	Torque Arm Bracket (S550)	1
9	AWS0428	M12 x 280 Bolt	2
10	AWS0431	STS Harness Protector (9560/70)	1
11	AWS0367	3VX1180-3 Belt	1
12	AWS0594	STS Drive Adaptor (S550)	1
13		1 <sup>1</sup> / <sub>4</sub> " NC x 1 <sup>1</sup> / <sub>4</sub> " Bolt	4
14		1 <sup>1</sup> / <sub>4</sub> " NC Nylock Nut	8
15		3 <sup>3</sup> / <sub>8</sub> " NC x 3 <sup>3</sup> / <sub>4</sub> " Carriage Bolt	5
16		3 <sup>3</sup> / <sub>8</sub> " NC Flange Nut	5
17		3 <sup>3</sup> / <sub>8</sub> " NC x 1" Flange Hex Self Tap	3
18		5 <sup>5</sup> / <sub>16</sub> " NC x 1 <sup>1</sup> / <sub>4</sub> " Hex Bolt	2
16		5 <sup>5</sup> / <sub>16</sub> " NC Nylock Nut	2
20		1 <sup>1</sup> / <sub>4</sub> " NC x 1 <sup>1</sup> / <sub>2</sub> " Hex Bolt	4

**LARGE (9650,9750,9660,9760,9670,9770,9870,S660,S670,S680,S690):**

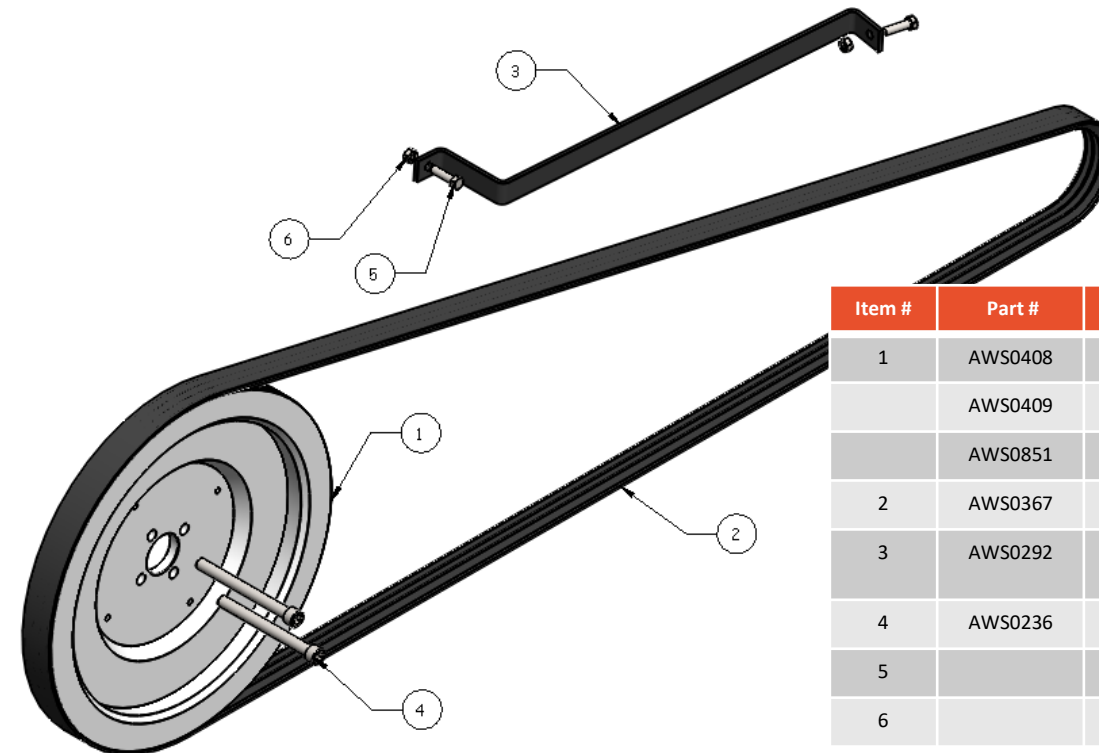

Item #	Part #	Description	Qty.
1	AWS0408	STS Aluminum Sheave	1
	AWS0409	STS Aluminum S Series Sheave	1
	AWS0851	Aluminum S Series Sheave (785000-)	1
2	AWS0367	3VX1180-3 Belt	1
3	AWS0292	STS Hose and Harness Protector (Not on S Series)	1
4	AWS0236	M12 x 130	2
5		5 <sup>5</sup> / <sub>16</sub> " NC 3 <sup>3</sup> / <sub>8</sub> 1 <sup>1</sup> / <sub>4</sub> " Hex Bolt	2
6		5 <sup>5</sup> / <sub>16</sub> " NC Nylock Nut	2

# John Deere Walker Combine Mount

(Chassis Assembly)

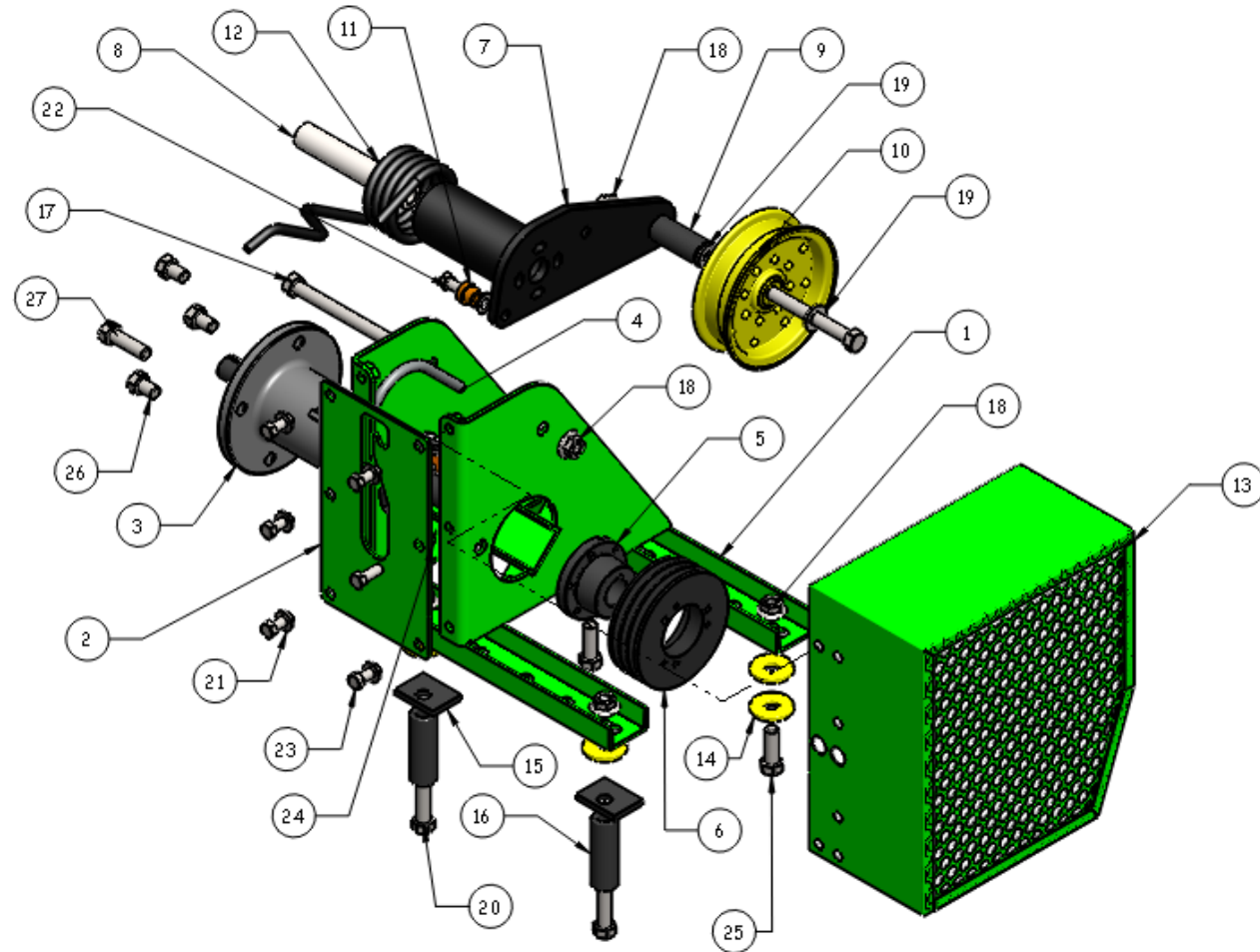

Item #	Part #	Description	Qty.
1	AWS0331	JD 50 Series Chassis	1
2	AWS0312	50 Series Chassis Center	1
3	AWS0127	14" Fan Shaft Assembly	1
		(See Breakout p. 24)	
4	AWS0039	3" Plated U-Bolt	2
5	AWS0033	SDS 1 1/8" Bushing	1
6	AWS0030	3V x 4.75-3 Sheave	1
7	AWS0261	Torsion Type Idler Arm	1
8	AWS0260	Idler Arm 5 5/8" Bushing	1
9	AWS0112	1/2" x 2 3/8" Spacer	1
10	AWS0111	A Drive Combine Idler	1
11	AWS0512	Tension Bushing	1
12	AWS0259	Torsional Spring	1
13	AWS0333	JD Combine Shield	1

Item #	Part #	Description	Qty.
14	AWS0233	1/2" x 1 5/8" - 1/4" Washer	6
15	AWS0234	Flat Side Washer	2
16	AWS0227	1/2" x 3" Spacer	2
17		1/2" NC x 6 1/2" Bolt	1
18		1/2" Flanged Hex Nut	6
19		1/2" Flat Washer	2
20		1/2" NC x 4 1/2" Bolt	3
21		3/8" Flat Washer	6
22		3/8" NC x 7/8" Bolt	1
23		3/8" NC x 1" Bolt	6
24		3/8" Flanged Hex Nut	4
25		1/2" NC x 1 1/2" Bolt	2
26		1/2" NC x 3/4" Bolt	3
27		1/2" NC x 1 3/4" Bolt	1

# John Deere 9000/10 Series Combine Mount

(Chassis Assembly)

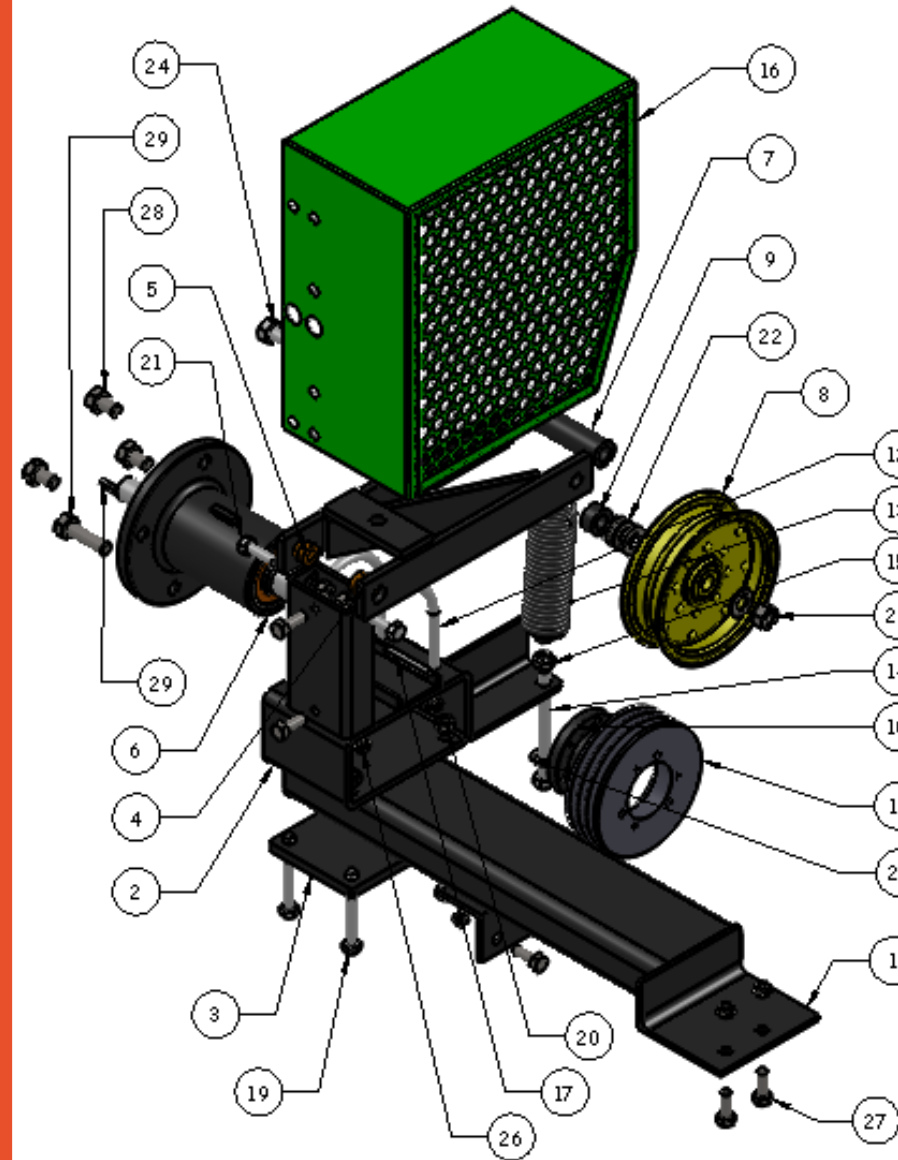

Item #	Part #	Description	Qty.
1	AWS0158	Mount Beam 9400/9410	1
	AWS0144	Mount Beam 9500/9510	1
	AWS0145	Mount Beam 9600/9610	1
2	AWS0146	00 Series Mount Bracket	1
3	AWS0192	Mount Bracket Plate	1
4	AWS0113	Idler Arm	1
5	AWS0512	Bushing	2
6	AWS0128	11" Fan Shaft Assembly (p.24)	1
7	AWS0017	1/2" x 3 1/2" Spacer	1
8	AWS0111	A Drive Idler (Combine)	1
9	AWS0226	1/2" x 1 1/2" Spacer	1
10	AWS0033	SDS 1 1/8" Bushing	1
11	AWS0136	3V x 5.00-3 Sheave	1
12	AWS0039	3" Plated U-Bolt	2
13	AWS0014	Spring Extension	1
14	AWS0015	7/16" NC x 5" Bolt	1
15	AWS0016	7/16" NC Jam Nut	1
16	AWS0333	JD Shield	1
17	AWS0034	1/4" x 2" Key	1
18	AWS0073	3/16" x 2" Key	1
19		3/8" NC x 3" Bolt	4
20		3/8" NC Locknut	6
21		1/2" NC x 6 1/2" Bolt	2
22		1/2" Flat Washer	3+
23		1/2" NC Locknut	1
24		1/2" NC x 6 1/2" Bolt	1
25		7/16" Flat Washer	1
26		3/8" NC Flange Nut	8
27		3/8" NC x 1" Bolt	6
28		1/2" NC x 3/4" Bolt	3
29		3/8" NC x 1 3/8" Bolt	1



## JD Walker

Item #	Part #	Description	Qty.
1	AWS0411	60 Series Conv. Sheave	1
2	AWS0316	S.S. Washer	1
3	AWS0139	3v x 1060-3 Belt	1
4		3/8" NC 1 1/4" Hex Bolt	6

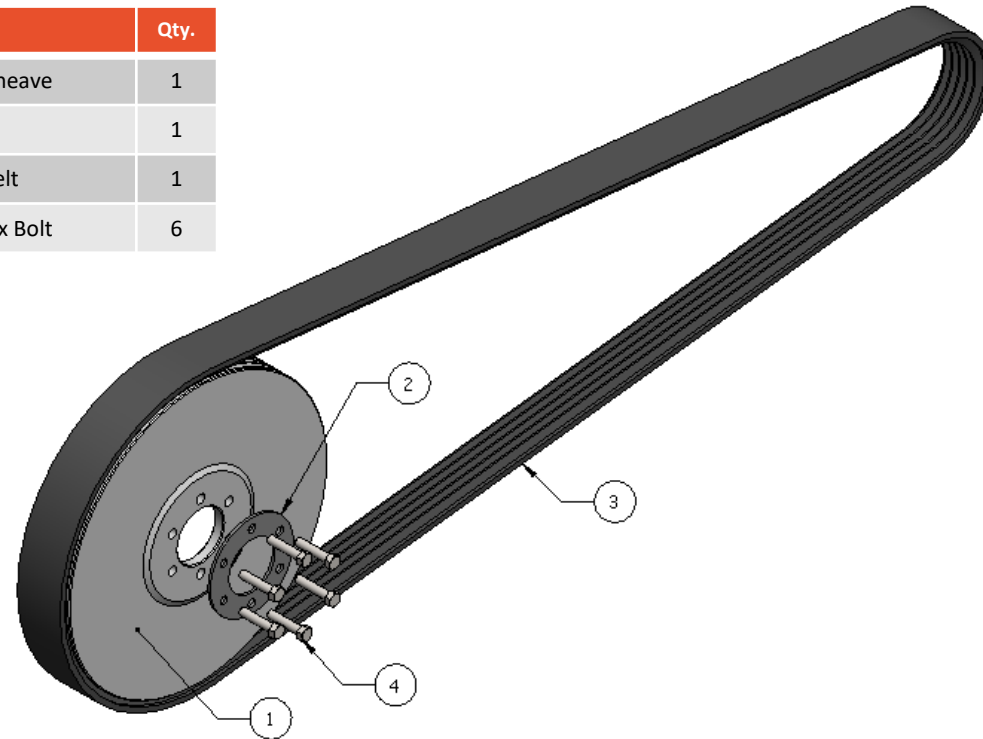

## 9000/10 Series

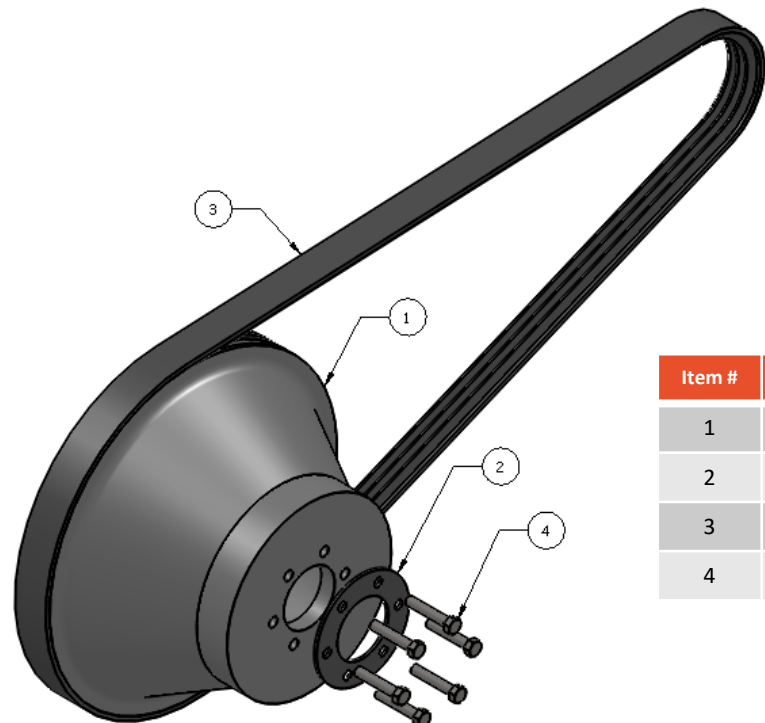

Item #	Part #	Description	Qty.
1	AWS0315	Aluminum Offset Sheave	1
2	AWS0316	S.S. Washer	1
3	AWS0139	3V x 1060-3 Belt	1
4		3/8 NC 2" Hex Bolt	6

## STS:

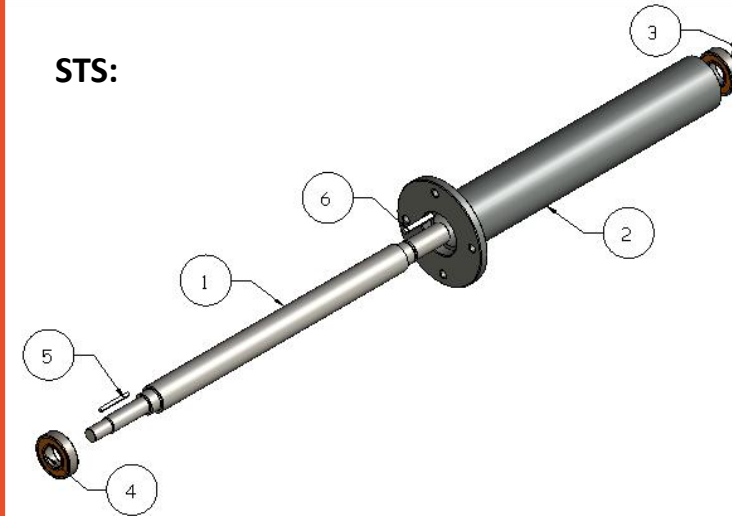

## 25" Fan Shaft Assembly – AWS0129

Item #	Part #	Description	Qty.
1	AWS0221	25" STS Fan Shaft	1
2	AWS0222	17.5" Fan Shaft Housing	1
3	AWS0036	1 1/8" Snap Ring Extension	1
4	AWS0037	6206-2RS C3 Fan Shaft Bearing	2
5	AWS0073	3/16" x 2" Key	1
6	AWS0034	1/4" x 2" Key	1

## 50 Series/Case IH/NH:

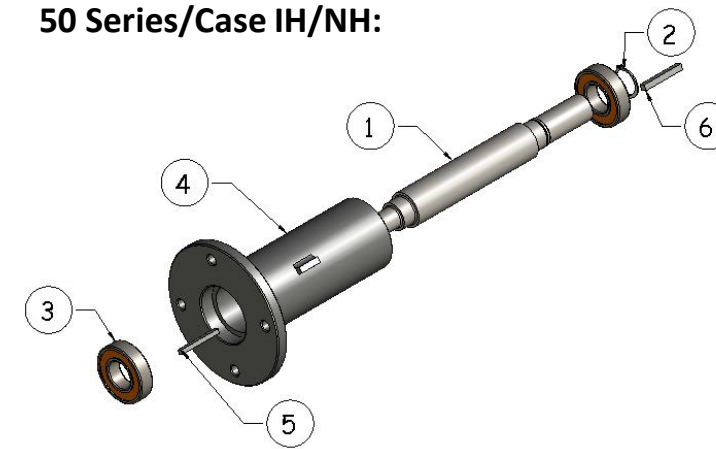

## 14" Fan Shaft Assembly – AWS0127

Item #	Part #	Description	Qty.
1	AWS0035	14" Fan Shaft	1
2	AWS0036	1 1/8" Snap Ring Extension	1
3	AWS0037	6206-2RS C3 Fan Shaft Bearing	2
4	AWS0038	7.5" Fan Shaft Housing	1
5	AWS0073	3/16" x 2" Key	1
6	AWS0034	1/4" x 2" Key	1

## 9000/10 Series

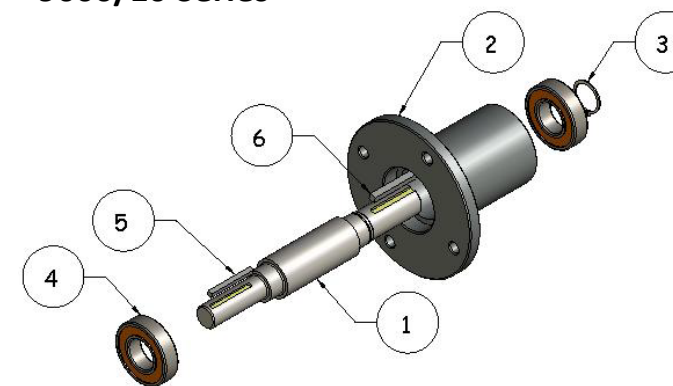

## 11" Fan Shaft Assembly – AWS0128

Item #	Part #	Description	Qty.
1	AWS0182	11" Fan Shaft	1
2	AWS0183	4.75" Fan Shaft Housing	1
3	AWS0036	1 1/8" Snap Ring Extension	1
4	AWS0037	6206-2RS C3 Fan Shaft Bearing	2
5	AWS0073	3/16" x 2" Key	1
6	AWS0034	1/4" x 2" Key	1

\*Temp Farm Equipment offers free rebuild service. Please call for details.



# John Deere 600F Series Mount Arms

# John Deere 635D and 635FD Mount Arms

JD 600F Mount Arm Assembly – AWS0404

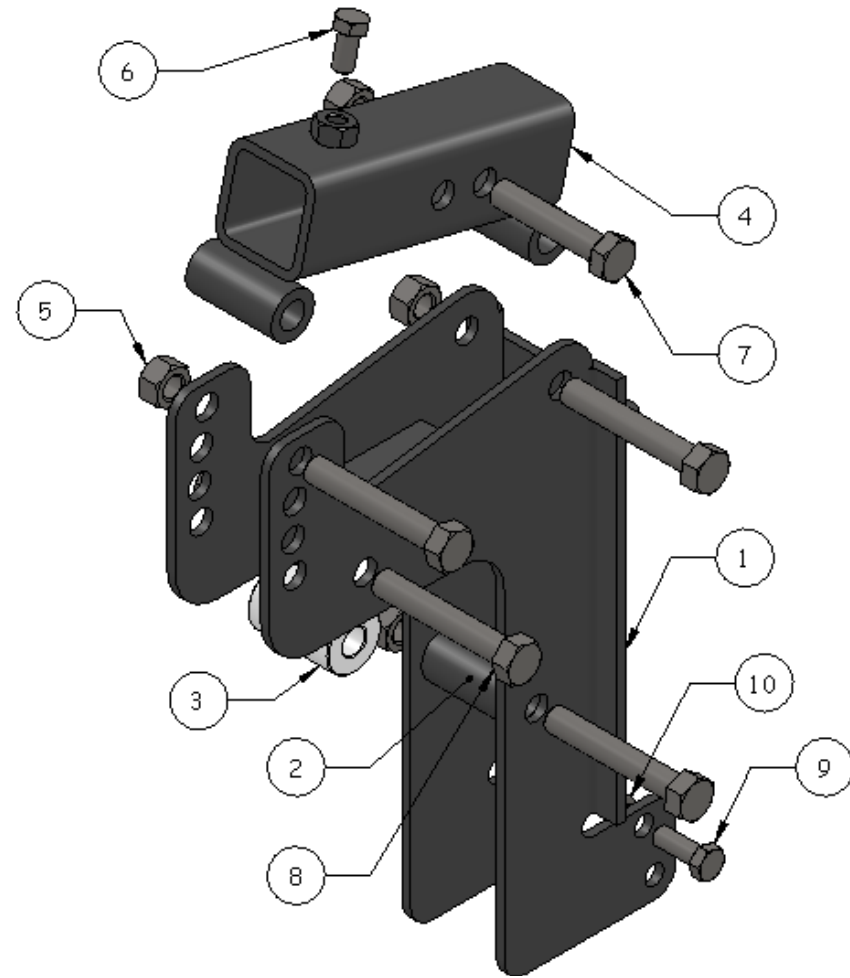

Item #	Part #	Description	Qty.
1	AWS0477	JD Mount Arm Bracket	1
2	AWS0398	1/2" x 1 7/8" Spacer	1
3	AWS0538	1 7/8" Roller	1
4	AWS0487	Mount Arm Tube	1
5		1/2" Top Lock Nut	5
6		3/8" NC x 3/4" Bolt	1
7		1/2" x 2 1/2" Bolt	1
8		1/2" x 3" Bolt	4
9		3/8 x 1" Bolt	2
10		3/8" Flange Hex Nut	2

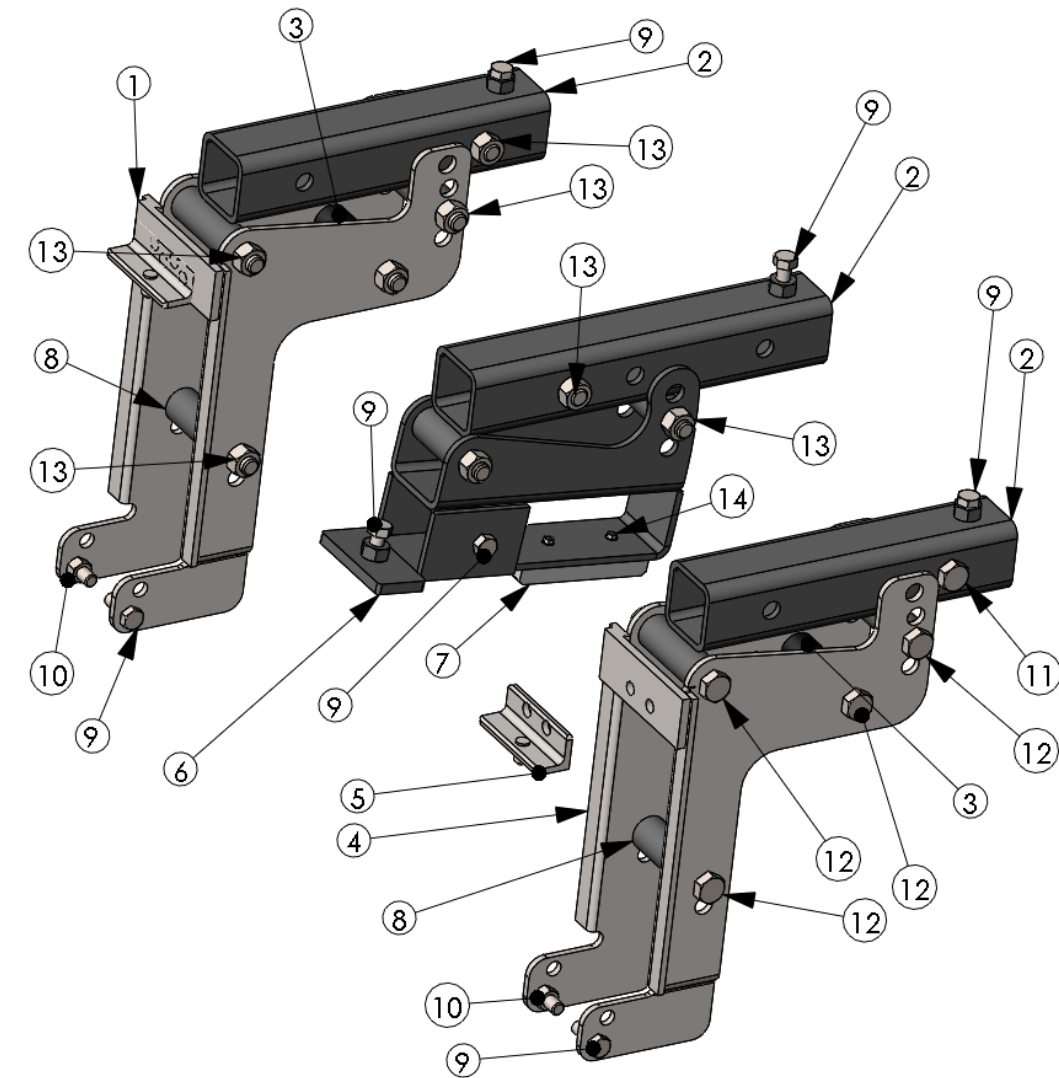

Item #	Part #	Description	Qty.
1	AWS0895	LH Mount Arm Bracket	
2	AWS0646	Mount Arm Tube	
3		2 1/2" Roller	
4	AWS0895	RH Mount Arm Bracket	
5	AWS0913	635FD RH Mount Arm Angle Adaptor	1
6	AWS0565	1/2" x 2 1/2" Spacer	

Item #	Part #	Description	Qty.
7		3/8 x 1" Bolt	
8		3/8" Flange Hex Nut	
9		1/2" x 2 1/2" Bolt	
10		1/2" x 4" Bolt	
11		1/2" NC Stover Nut	

# John Deere 640FD Mount Arms (Pre-2015)

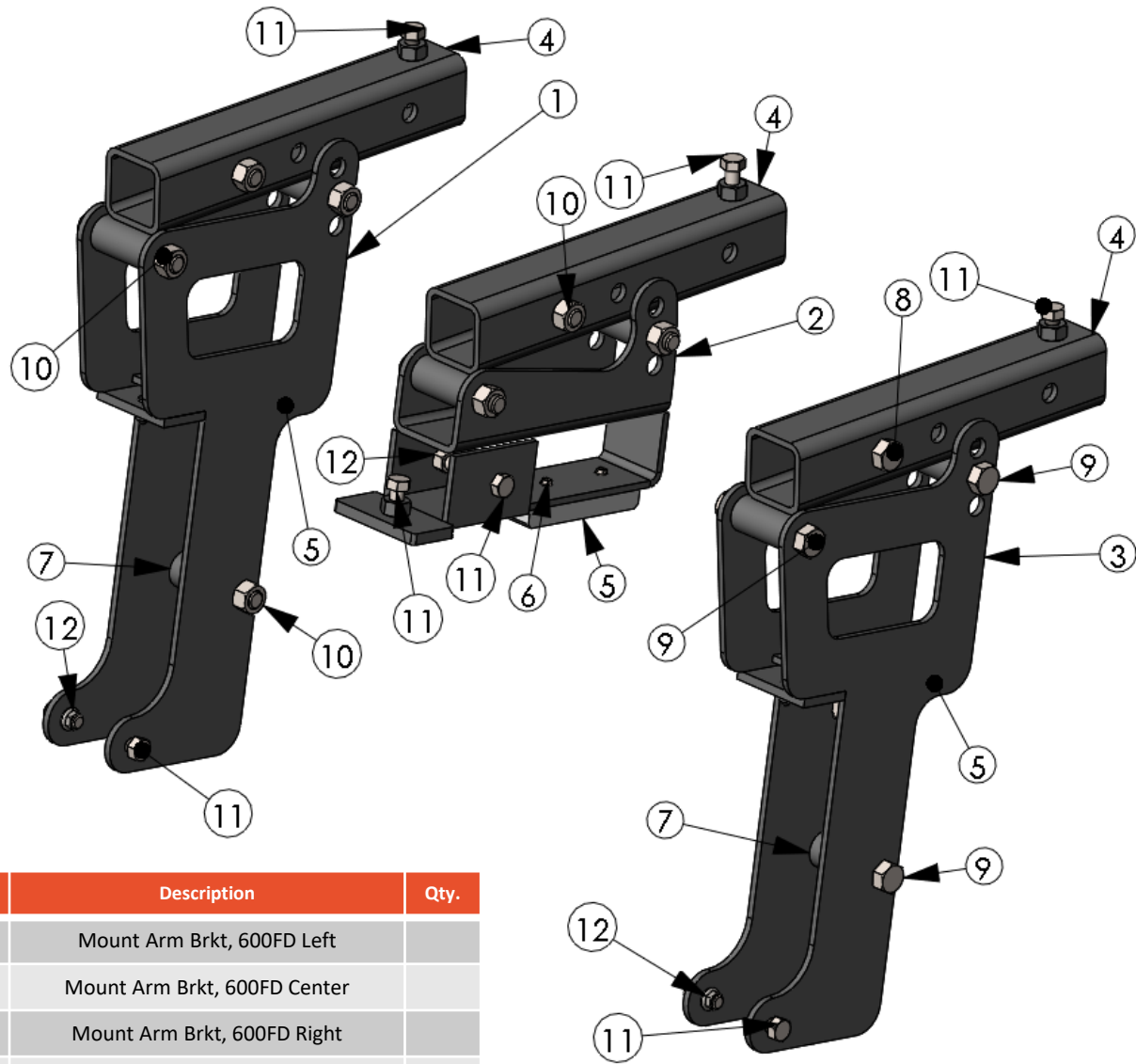

Item #	Part #	Description	Qty.
1	AWS0542	Mount Arm Brkt, 600FD Left	
2	AWS0543	Mount Arm Brkt, 600FD Center	
3	AWS0544	Mount Arm Brkt, 600FD Right	
4	AWS0537	11" Mount Arm Tube	
5	AWS0360	Wide Slide Block	
6		1/4" NC x 3/4" Bolt	
7		1 7/8" Steel Roller	
8		2 1/2" NC x 1/2" Bolt	
9		1/2" x 3" Bolt	
10		1/2" Lock Nut	
11		3/8 x 1" Bolt	
12		3/8 Flange Nut	
13		3/8 Lock Nut	

# John Deere 600 Mount Arm (Post-2015)

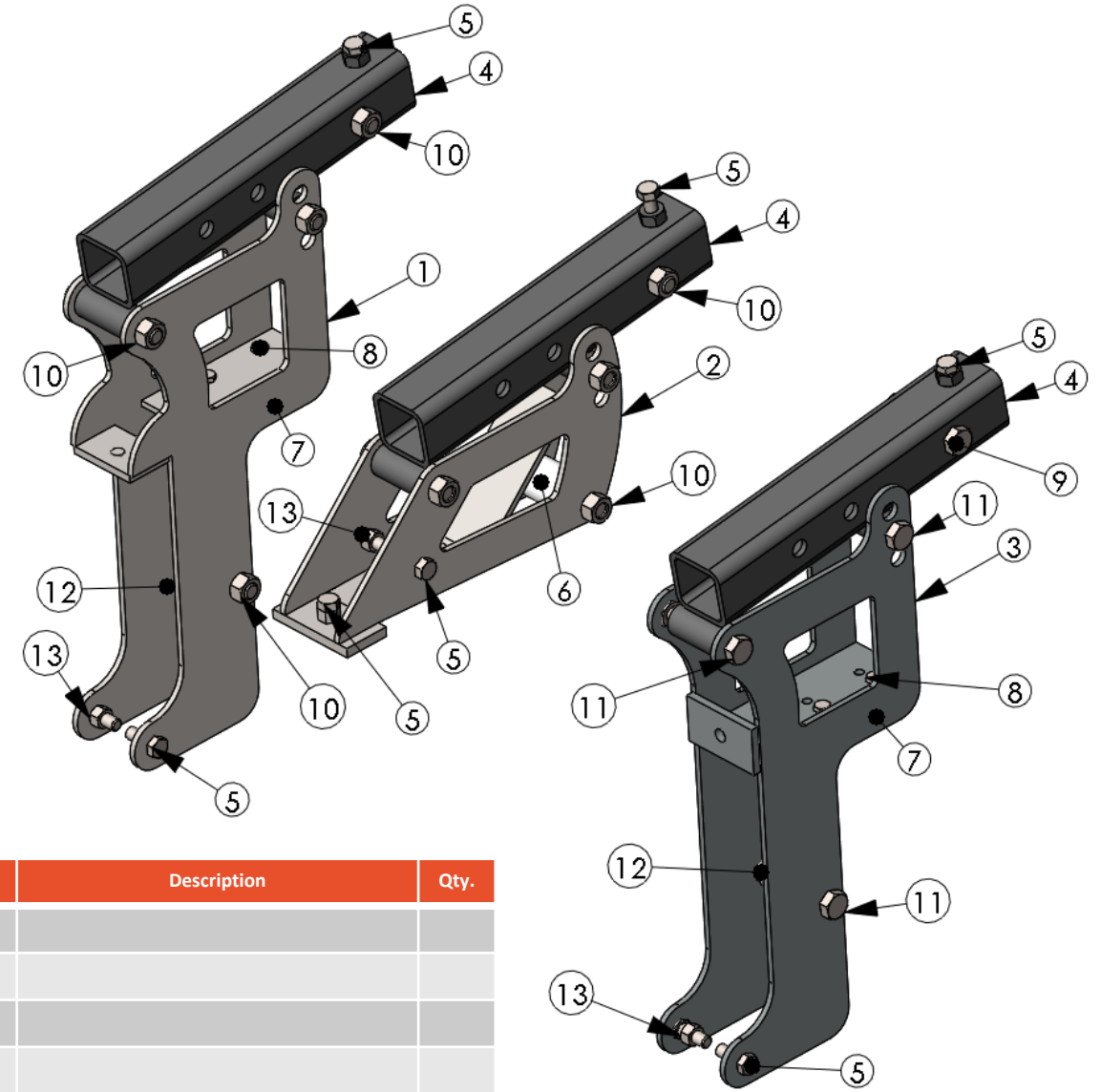

Item #	Part #	Description	Qty.
1			
2			
3			
4			
5			
6			
7			
8			
9			
10			
11			
12			
13			

# JD 900 Mount Arms (Left)

# JD 900 Mount Arms (Right)

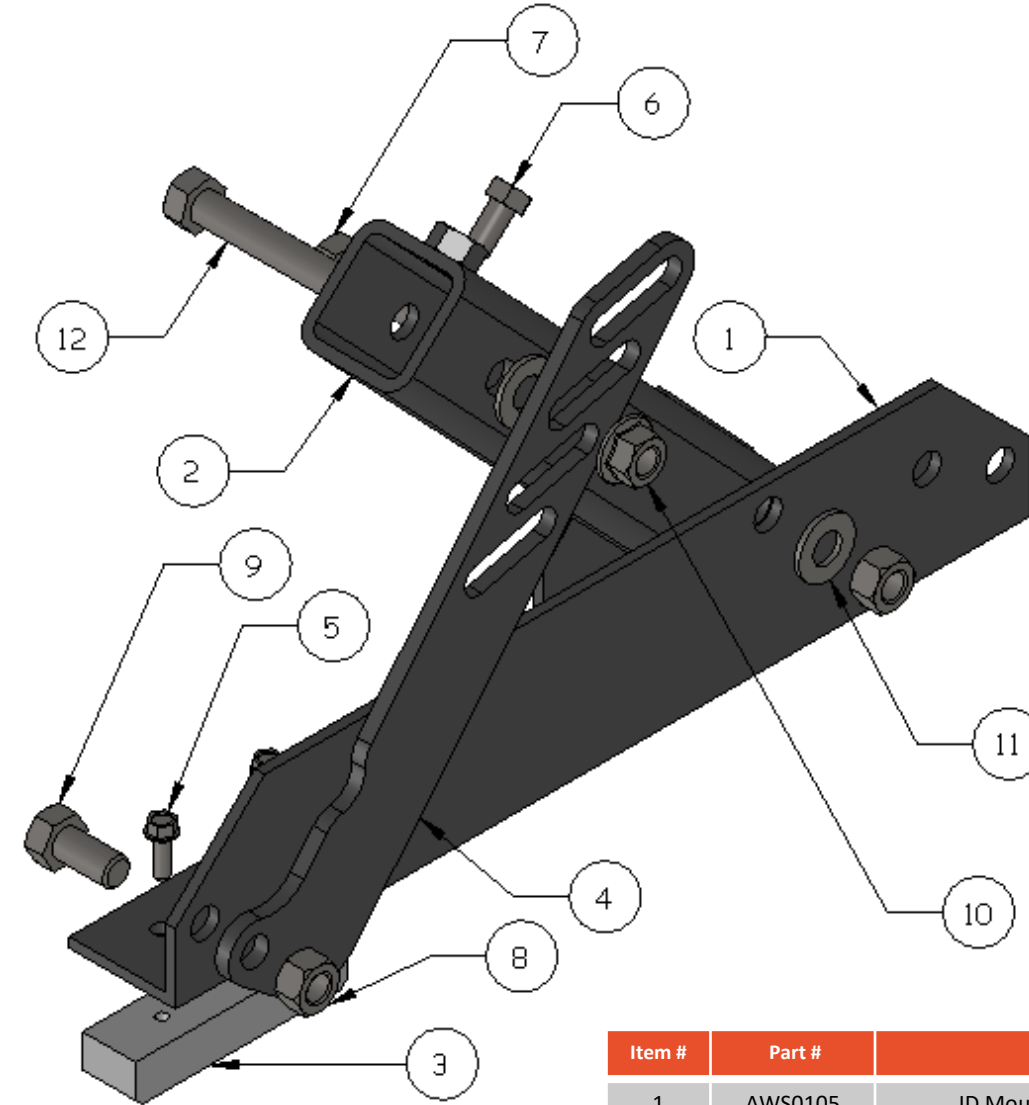
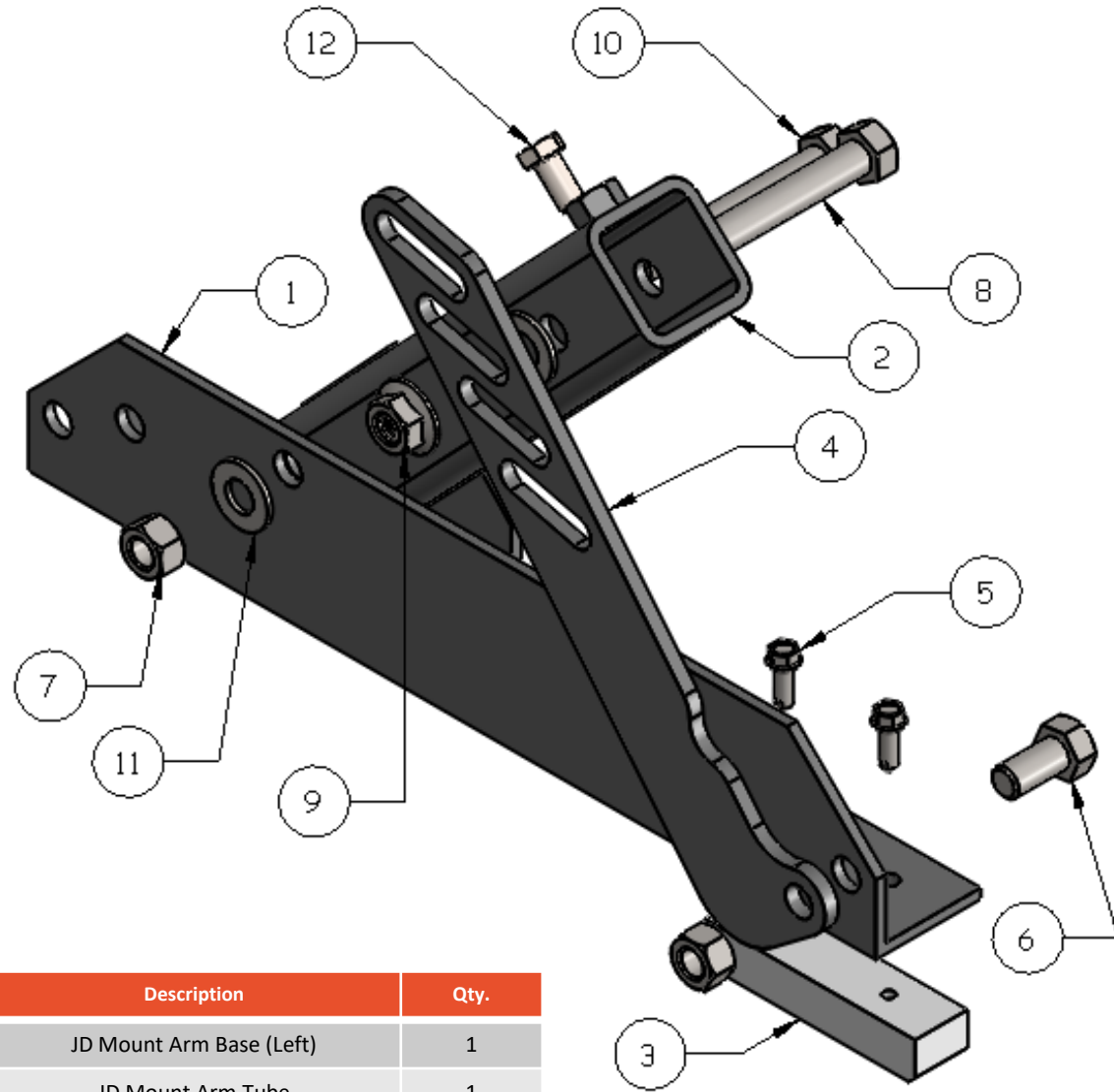

Item #	Part #	Description	Qty.
1	AWS0104	JD Mount Arm Base (Left)	1
2	AWS0207	JD Mount Arm Tube	1
3	AWS0359	JD Mount Arm Slide	1
4	AWS0109	10" Adjustment Link	1
5		1/4 NC x 3/4 Thread Cut Hex Type F S.S.	2
6		1/2" NC x 1" Bolt	1
7		1/2" Top Lock Nut	2
8		1/2" x 3" Bolt	1
9		1/2" Flange Hex Nut	1
10		3/8" x 3 1/2" Bolt	1
11		1/2" Flat Washer	2
12		3/8" NC x 3/4" Bolt	1

Item #	Part #	Description	Qty.
1	AWS0105	JD Mount Arm Base (Left)	1
2	AWS0207	JD Mount Arm Tube	1
3	AWS0359	JD Mount Arm Slide	1
4	AWS0109	10" Adjustment Link	1
5		1/4 NC x 3/4 Thread Cut Hex Type F S.S.	2
6		3/8" NC x 3/4" Bolt	1
7		1/2" NC x 3 1/2" Bolt	2
8		1/2" Top Lock Nut	2
9		1/2" x 1" Bolt	1
10		1/2" Flange Hex Nut	1
11		1/2" Flat Washer	2
12		1/2" x 3" Bolt	1



# Case Chassis Assembly (Primary)

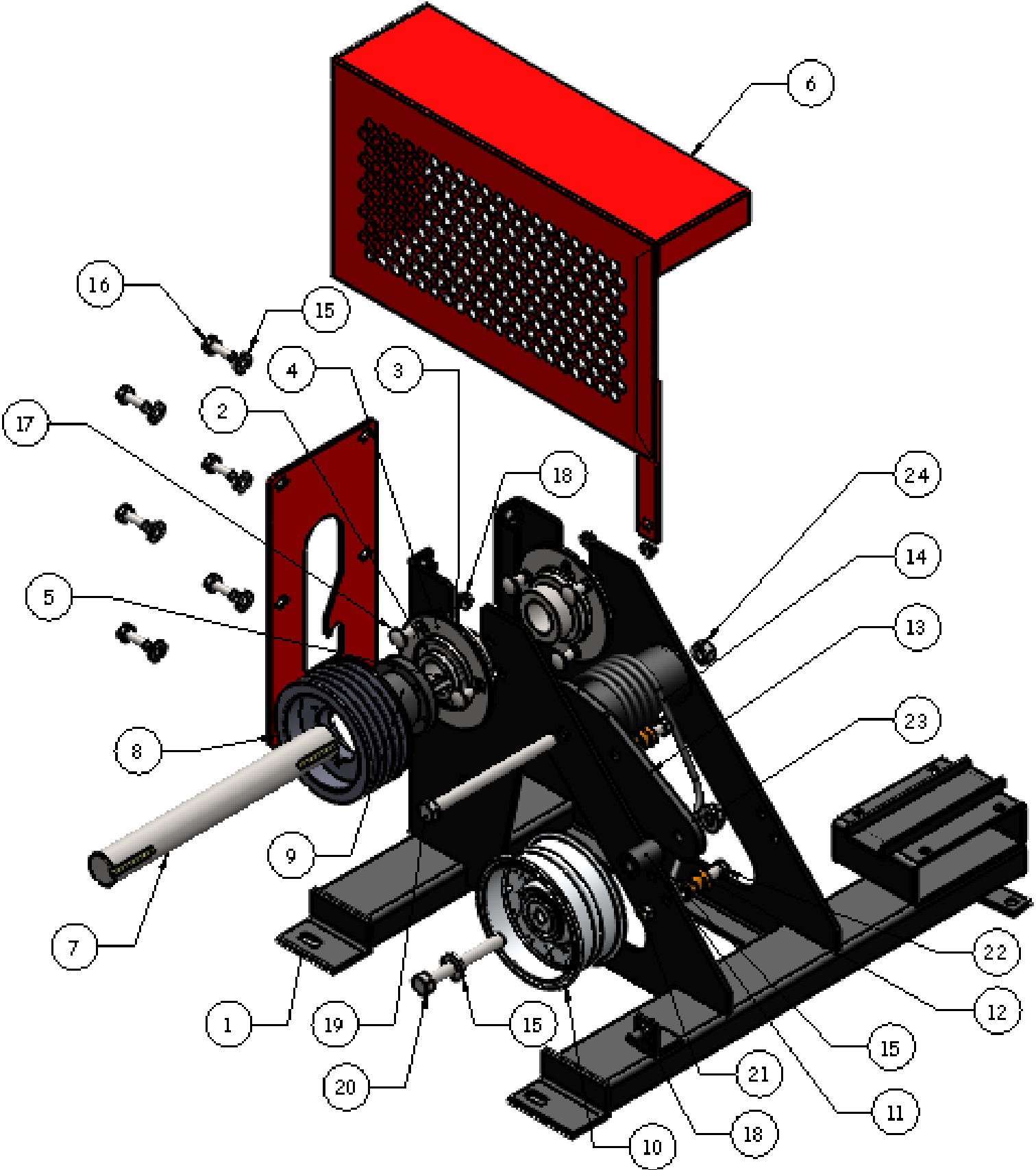

Item #	Part #	Description	Qty.
1	AWS0015	Case Combine Mount Chassis	1
2	AWS0003	1 <sup>3</sup> / <sub>8</sub> " WR UNA207-22G Bearing	2
3	AWS0001	PF207 Bearing Flange	2
4	AWS0420	PF207-G Greasable Flange	2
5	AWS0011	5/16" x 2" Key	2
6	AWS0280	Primary Case/NH Sheild	1
7	AWS0255	Secondary Combine Shaft	1
8	AWS0251	3V x 5.00-5 Sheave	1
9	AWS0305	SDS 1 <sup>3</sup> / <sub>8</sub> " Bushing	1
10	AWS0258	Case Combine Mount Idler	1
11	AWS0337	1/2" I.D. x 1 <sup>3</sup> / <sub>8</sub> " Spacer	1
12	AWS0512	Tensioner Bushing	2
13	AWS0261	Torsion Type Idler Arm	1
14	AWS0259	Torsion Type Spring	1
15		1/2" Washer	5+/-
16		3/8" x 1" Bolt	6
17		3/8" x 1" Carriage Bolt	6
18		3/8" Series Flange Nut	7
19		1/2" x 6 <sup>1</sup> / <sub>2</sub> " Bolt	1
20		1/2" x 4" Bolt	1
21		3/8" Stover Nut	1
22		3/8" x 1 <sup>1</sup> / <sub>4</sub> " Bolt	1
23		1/2" Series Flange Nut	1
24		1/2" Stover Nut	1

- Note:
- Use multiple 1/2" washers to align primary idler and primary pulley.
  - Primary belt is AWS0260 (not shown)
  - Always tighten lock collars on bearings in the direction of rotation
  - Use hardware provided with bushing set to attach sheave to bushing
  - Bolt shield over top of chassis centre plate
  - AWS0260 spacer used inside of idler arm

# Case Chassis Assembly (Secondary)

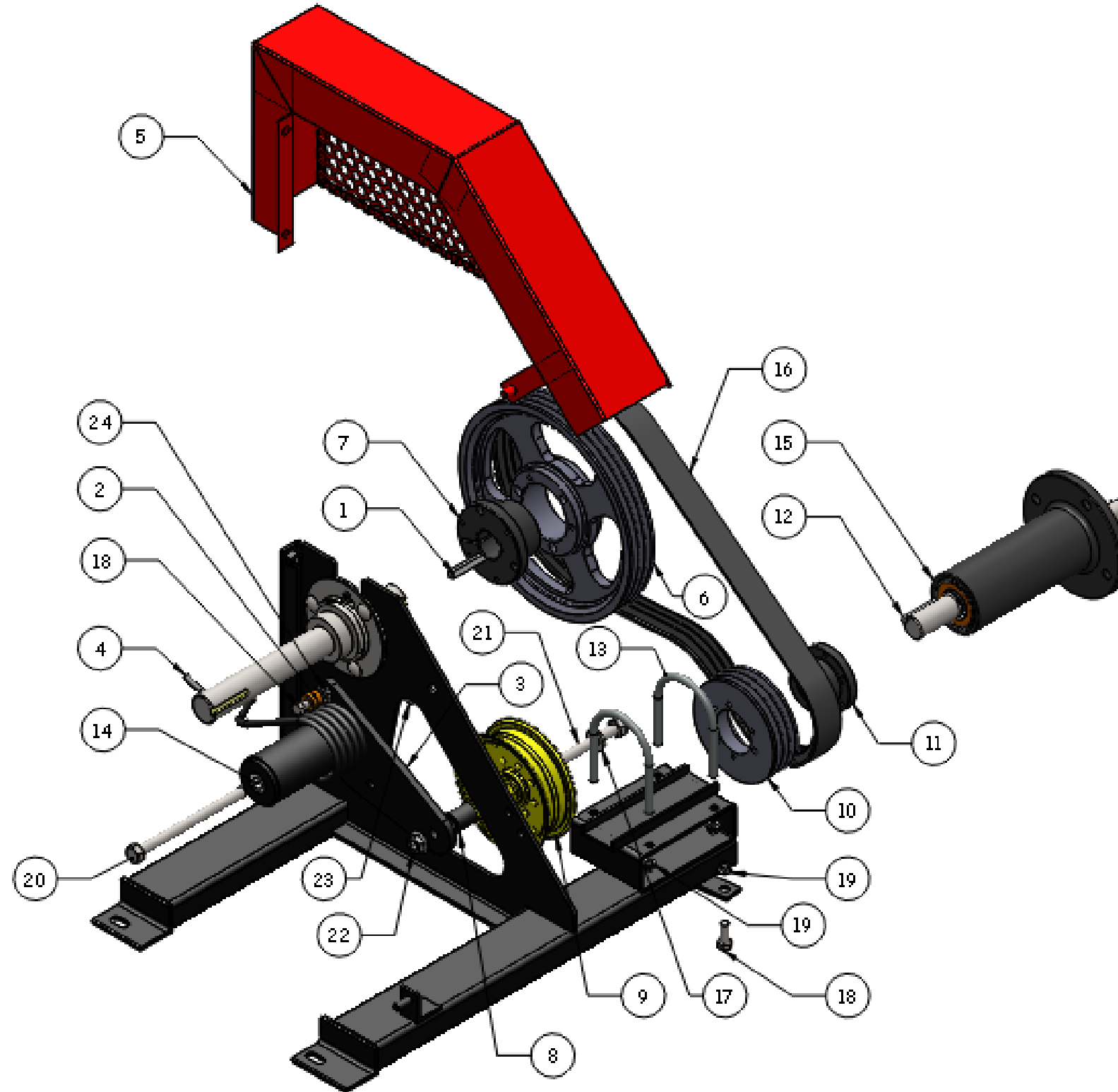

Item #	Part #	Description	Qty.
1	AWS0011	5/16" x 2" Key	1
2	AWS0512	Tensioner Bushing	1
3	AWS0261	Torsion Type Idler Arm	1
4	AWS0259	Torsion Type Spring	1
5	AWS0279	Secondary Case/NH Shield	1
6	AWS0289	3V x 10.6-3 Sheave	1
7	AWS0028	3/8" SK Bushing	1
8	AWS0018	1/2" I.D. x 1 3/16" Spacer	1
9	AWS0111	A Drive Idler (Combine)	1
10	AWS0136	3V x 5.00-3 Sheave	1
11	AWS0033	SDS 1 1/8" Bushing	1
12	AWS0034	1/4" x 2" Key	1
13	AWS0039	3" U-Bolt	2
14	AWS0260	5.6" Idler Bushing	1
15	AWS0127	14" Fan Shaft Assembly (p.24)	1
16	AWS0486	3V x 530-3 Belt	1
	AWS0253	3V x 560-3 Belt (Pre-2010)	1
17		1/2" Flat Washer	5+/-
18		3/8" x 1 Bolt	3
19		3/8" Series Flange Nut	6
20		1/2" x 6 1/2" Bolt	1
21		1/2" x 4" Bolt	1
22		1/2" Series Flange Nut	1
23		1/2" Stover Lock Nut	1
24		3/8" Flat Washer	5+/-

**Note:**

- Align bushing on secondary shaft with chamfer edge at the end of the shaft
- Use multiple 1/2" washers to align idler with sheave
- Use multiple 3/8" washers on idler arm to push bushing out
- Use hardware provided with bushing set to attach sheave to bushing

# Case 66 Drive Components

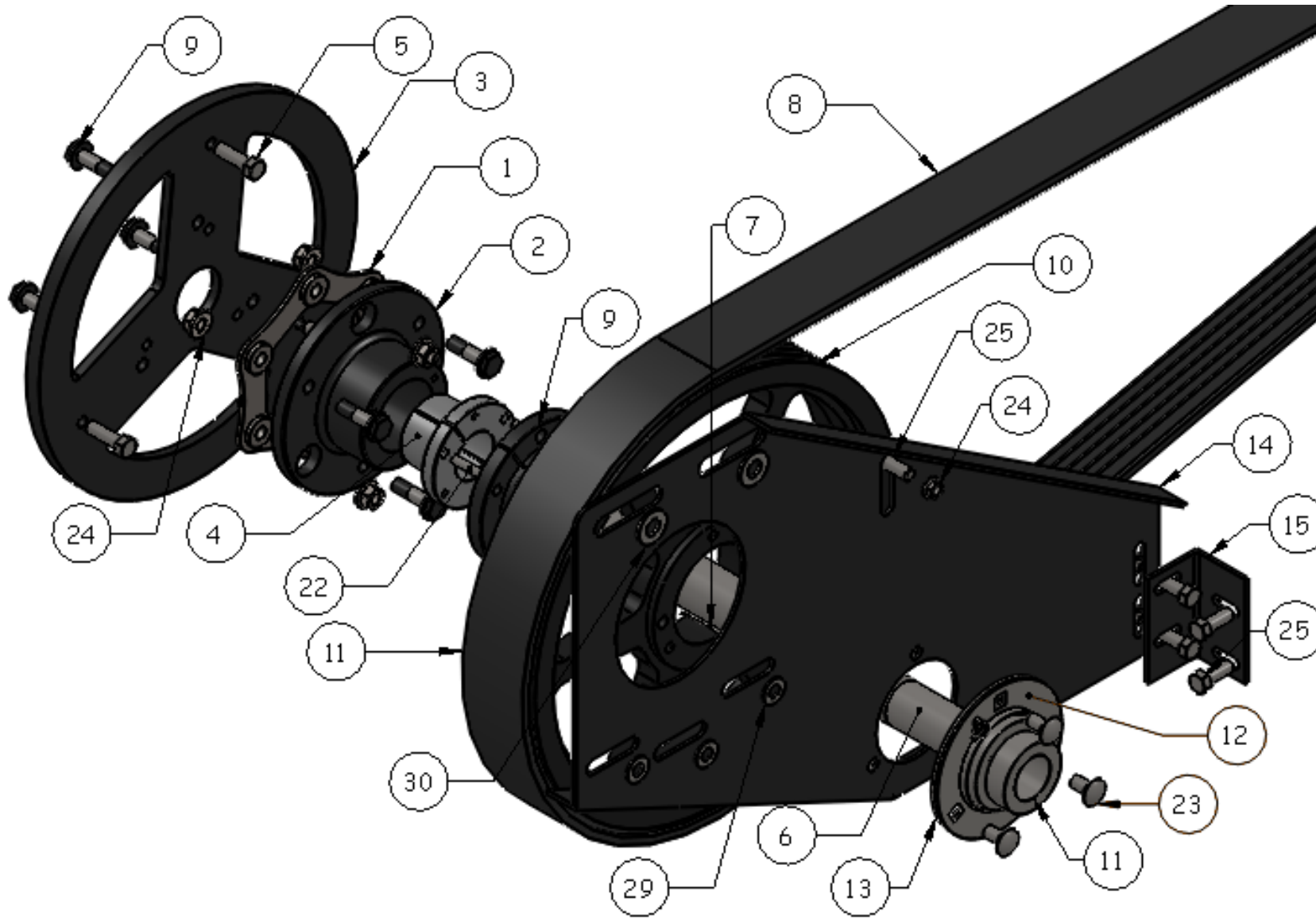

Item #	Part #	Description	Qty.	Item #	Part #	Description	Qty.
1	AWS0640	Coupler Disc with Bolts	1	13	AWS0420	Greasable Bearing Flange	1
2	AWS0642	Coupler Hub	1	14	AWS0291	Case 66 Bearing Support	1
3	AWS0290	Case 66 Plate	1	15	AWS0299	Case 66 Support Angle	1
4	AWS0436	SD 1 1/2" Bushing	1	16	AWS0285	Case Harness Protector	1
5	AWS0166	3/8" NC x 1 1/2" Grade 8 Hex Bolt	3	17	AWS0277	Case Door	1
6	AWS0474	NH 18.5" Shaft	1	18	AWS0278	Case Lower Panel	1
7	AWS0426	3/8" #29 Woodruff Key	2	19	AWS0298	Case 66 Platform Support	1
8	AWS0252	3V x 1120-5 Belt	1	20	AWS0282	Case Platform Support Plate	1
9	AWS0437	1 1/2" SF Bushing	1	21		3/8" NC 1" Truss Head Screw	3
10	AWS0300	3V x 14.0-5 Sheave	1	22		1/4" NC x 1 1/4" Hex Bolt	3
11	AWS0003	1 3/8" Bearing	1	23		3/8" NC x 3/4" Carriage Bolt	3
12	AWS0001	PF207 Bearing Flange	1	24		3/8" NC Hex Flange Nut	11
				25		3/8" NC x 1" Hex Bolt	5
				26		1/2" NC x 2" Grade 8 Hex Bolt	2
				27		1/2" NC x 8" Hex Bolt	2
				28		1/2" NC Stover Locknut	2
				29		3/8" Flat Washer	3
				30		1/2" Flat Washer	2

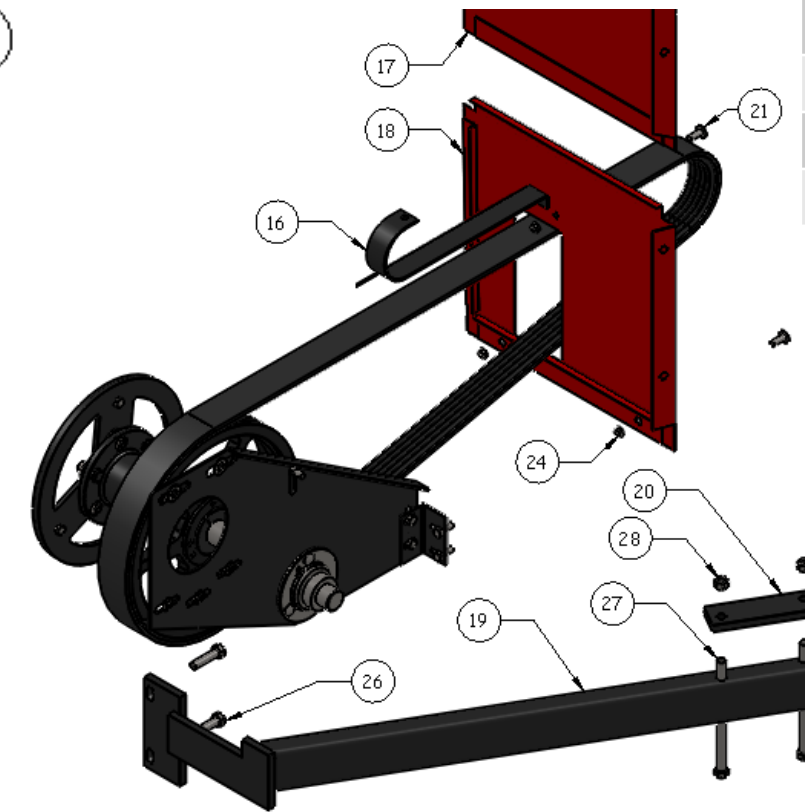



# Case 88 Drive Components

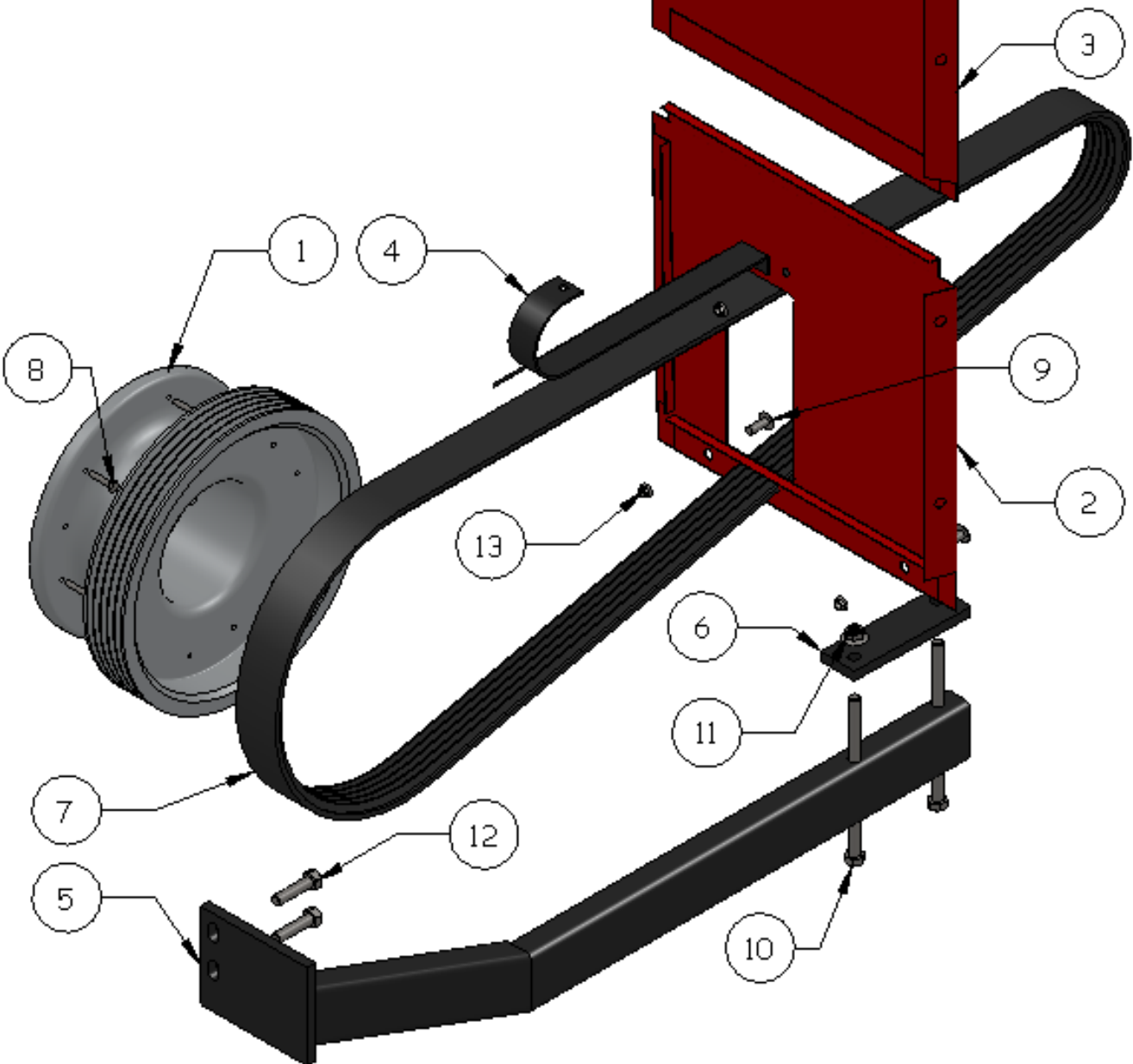

Item #	Part #	Description	Qty.
1	AWS0256	Case 88 Aluminum Sheave	1
2	AWS0278	Case Lower Panel	1
3	AWS0277	Case Door	1
4	AWS0285	Case Harness Protector	1
5	AWS0281	Case 88 Platform Support	1
6	AWS0282	Case Platform Support Plate	1
7	AWS0252	3V x 1120-5 Belt	1
8		1/4" NC 1 1/4" Hex Bolt	1

Item #	Part #	Description	Qty.
9		3/8" NC x 1" Truss Head Screw	6
10		1/2" NC x 8" Hex Bolt	3
11		1/2" NC Stover Locknut	2
12		1/2" NC x 2" Grade 8 Hex Bolt	2
13		3/8" NC Hex Flange Nut	3

# Case 1020 Mount Arm Brackets

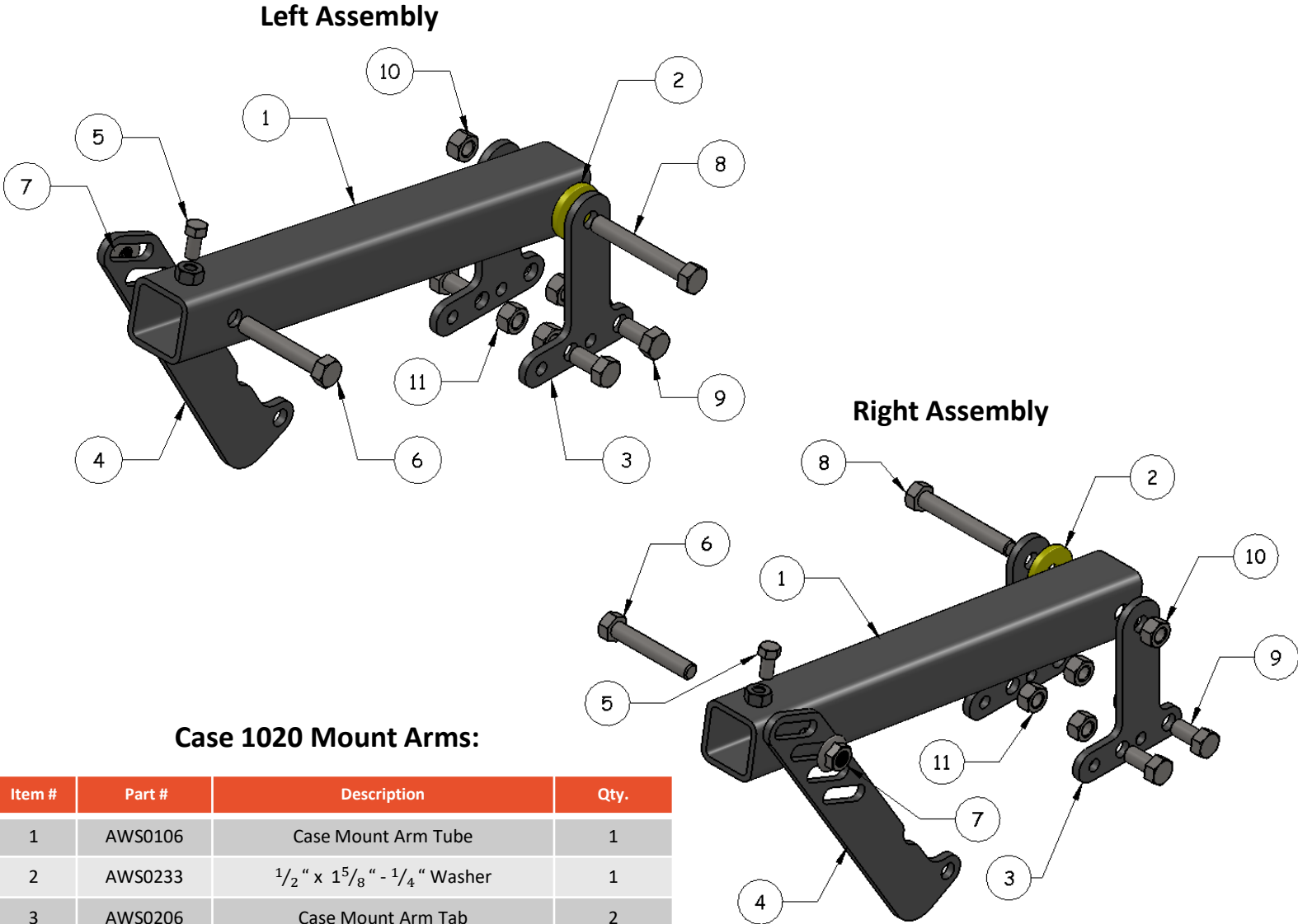

### Case 1020 Mount Arms:

Item #	Part #	Description	Qty.
1	AWS0106	Case Mount Arm Tube	1
2	AWS0233	1/2" x 1 5/8" - 1/4" Washer	1
3	AWS0206	Case Mount Arm Tab	2
4	AWS0109	11" Adjusting Link	1
5		3/8" NC x 3/4" Bolt	2
6		1/2" x 1" Bolt	1
7		1/2" Flange Nut	1
8		1/2" x 3 1/2" Bolt	1
9		1/2" x 1" Bolt -or- 3/8" x 1" Bolt	4
		(Depending on Reel Style)	
10		1/2" Top Lock Nut	1
11		1/2" Nut -or- 3/8" Nut	4

# Case 2020/NH 74C & 973 Mount Arm Brackets

# Case 3020/NH 740CF Mount Arm Brackets

## Case 2020 / NH 74C & 973 Late Model (Chain Drive Reel) (Bill of materials is for both left and right sets)

Item #	Part #	Description	Qty.
1	AWS0108	Agco/NH Mount Arm – Right	1
	AWS0107	Agco/NH Mount Arm – Left	
2	AWS0109	11" Adjusting Link	2
3	AWS0429	CNH 2074 Spacer	1
4		3/8" NC x 3/4" Bolt	3
5		1/2" NC x 3" Bolt	2
6		1/2" NC x 4" Bolt	2
7		1/2" Stover Locknut	4

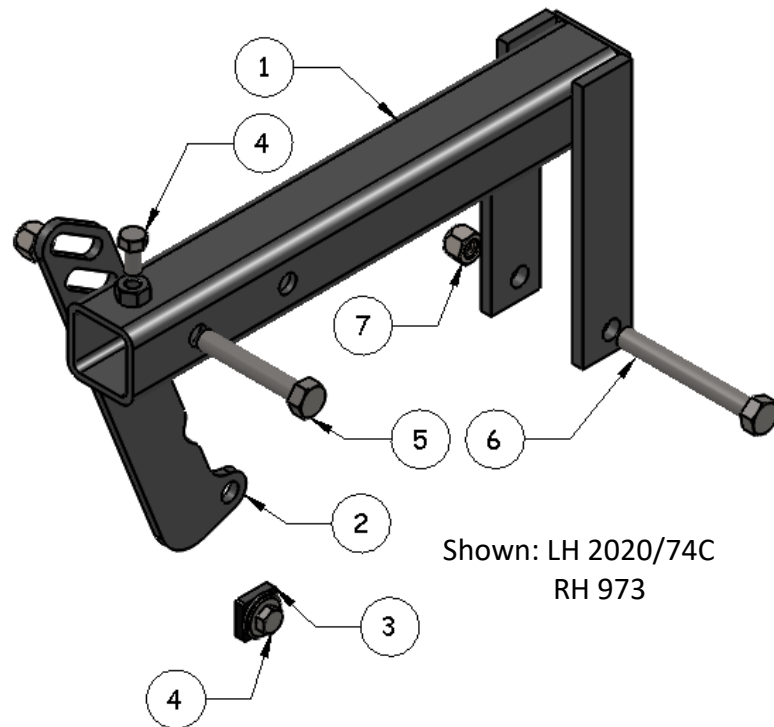

Shown: LH 2020/74C  
RH 973

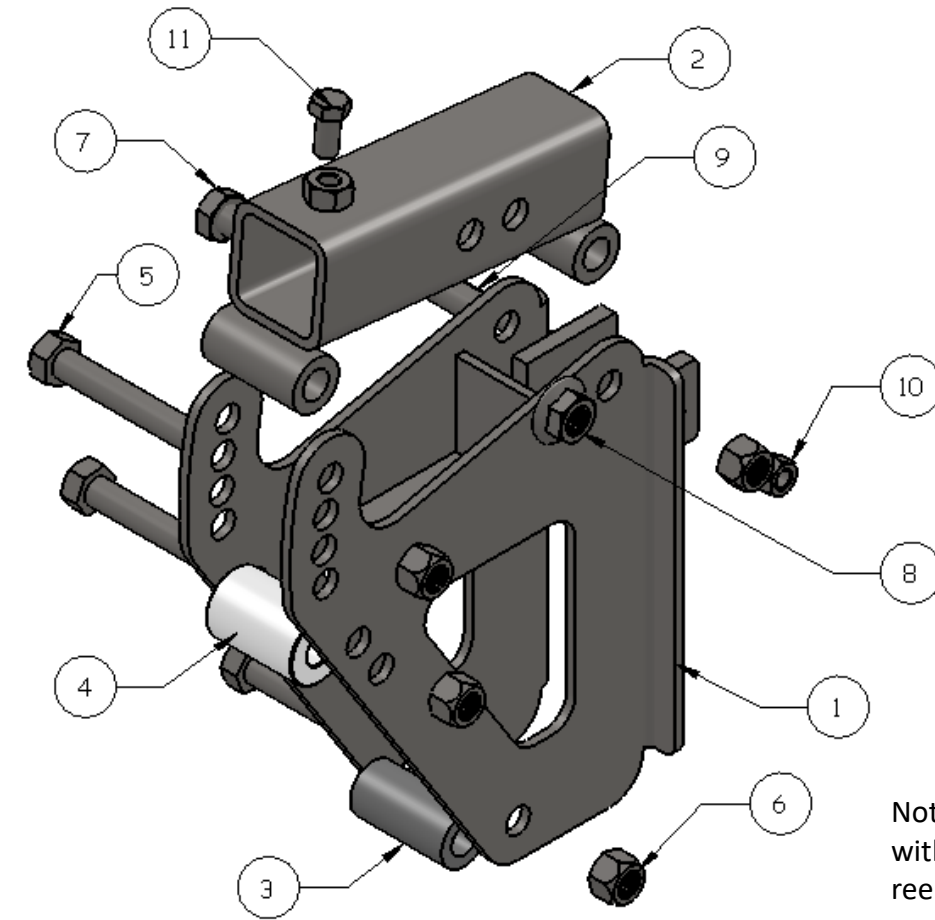

Note: Typically assembled  
with bolt heads to outside of  
reel

Shown: Right Hand Version

## CNH 3074 Mount Arm Assembly – AWS0513

Item #	Part #	Description	Qty.
1	AWS0507	CNH 3074 Mount Arm Bracket	1
2	AWS0487	Mount Arm Tube	1
3	AWS0459	1/2" x 2" Spacer	1
4	AWS0538	1 7/8" Roller	1
5		1/2" x 3" Bolt	4
6		1/2" Stover Locknut	4
7		1/2" x 2 1/2" Bolt	1
8		3/8" Flange Hex Nut	1
9		3/8" x 2 1/2" Bolt	1
10		3/8" Stover Locknut	1
11		3/8" NC x 3/4" Bolt	1

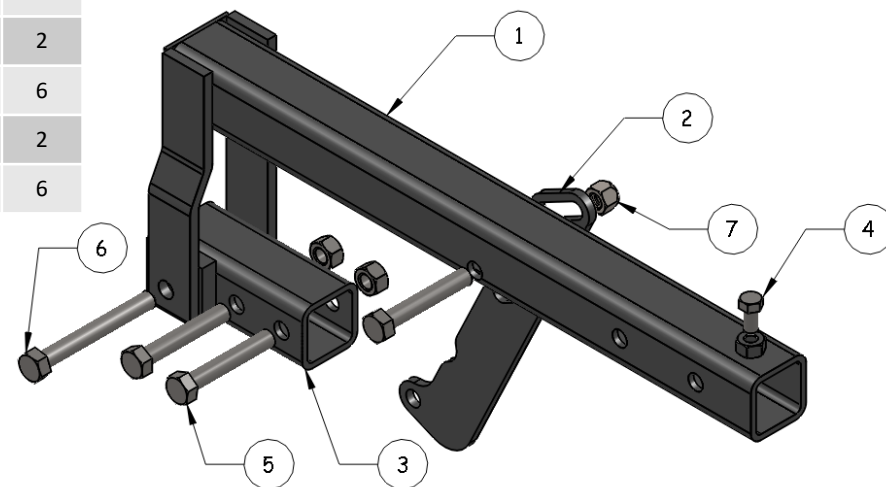

## Case 2020 / NH 74C Early Model (Direct Drive Reel) (Bill of materials is for both left and right sets)

Item #	Part #	Description	Qty.
1	AWS0357	Agco/NH U-2 Mount Arm – Right	1
	AWS0356	Agco/NH U-2 Mount Arm – Left	
2	AWS0109	11" Adjusting Link	2
3	AWS0378	CNH 2074 Manifold Bracket	2
4		3/8" NC x 3/4" Bolt	2
5		1/2" NC x 3" Bolt	6
6		1/2" NC x 4" Bolt	2
7		1/2" Stover Locknut	6

# MacDon FD75 Mount Arms

# MacDon FD70 Mount Arms

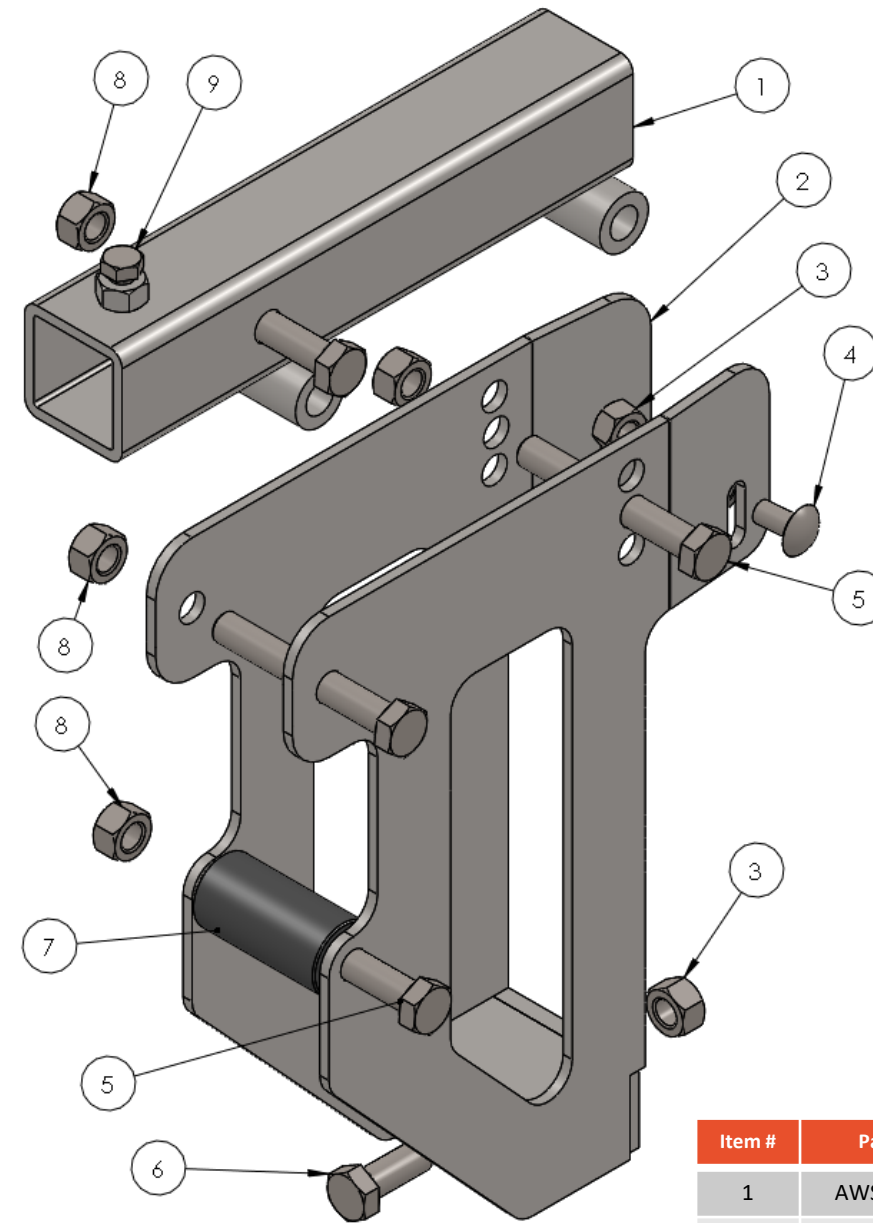
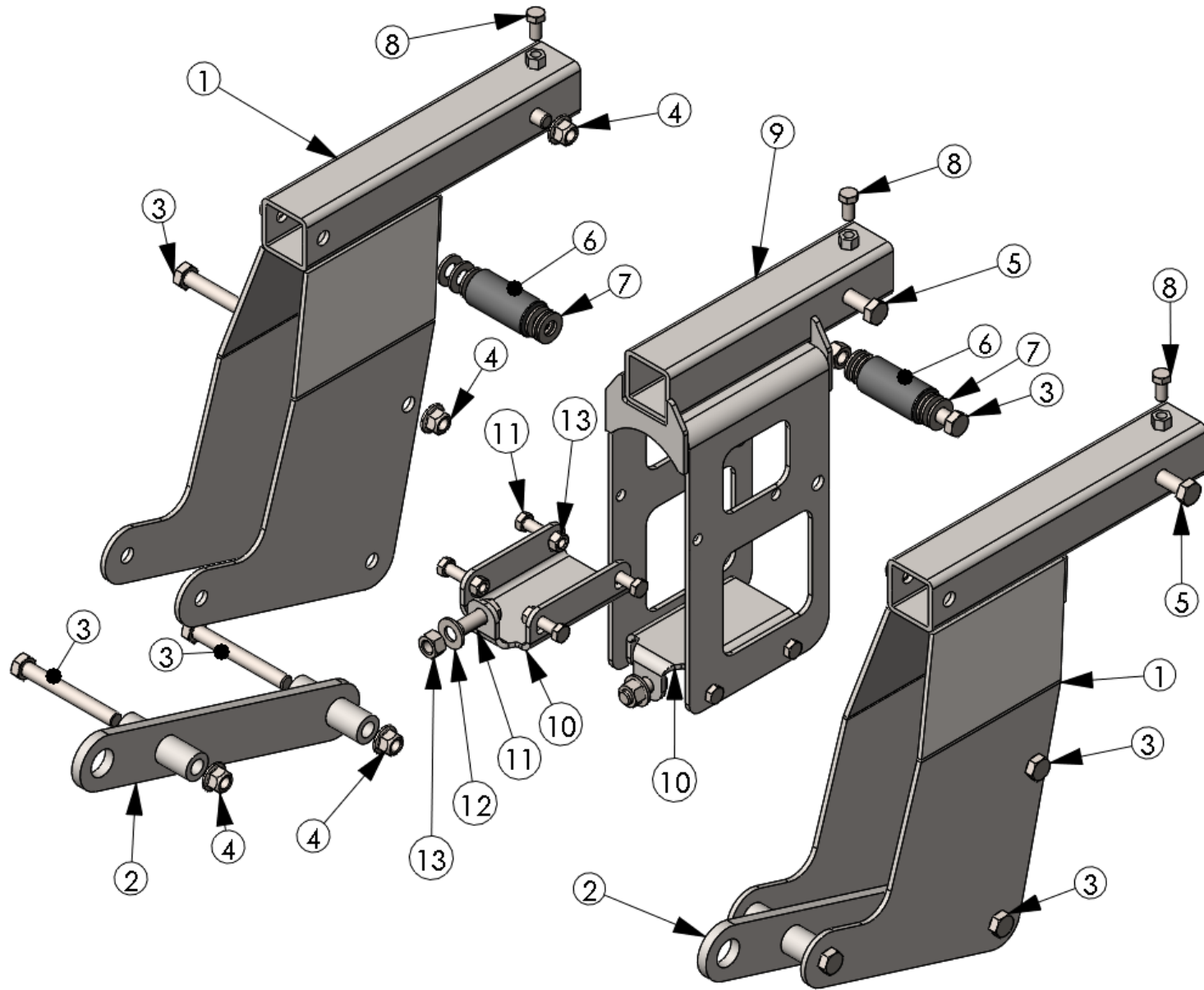

Item #	Part #	Description	Qty.
1	AWS0700	FD75 Outer Mount Arm Bracket	
2	AWS0701	FD75 Outer Mount Arm Link	
3		1/2" x 4" Bolt	
4		1/2" NC Stover Nut	
5		1/2" x 2 1/2" Bolt	
6		3" Roller	

Item #	Part #	Description	Qty.
7		3/8" x 1" Bolt	
8	AWS0703	FD75 Center Mount Arm Link	
9	AWS0702	FD75 Center Mount Arm Bracket	
10		1/2" x 1" Bolt	
11		1/2" Flange Hex Nut	
12		3/8" Flange Hex Nut	

Item #	Part #	Description	Qty.
1	AWS0510	FD70 Mount Arm Tube	1
2	AWS0509	FD70 Mount Arm Bracket	1
3		3/8" Flange Hex Nut	
4		1/4" x 3/4" Carriage Bolt	
5		3/8" x 2 1/2" Bolt	
6		1/2" x 1" Bolt	
7		2 1/2" Roller	
8		1/2" NC Stover Nut	
9		3/8" x 1" Bolt	



### NH Variable Speed Chassis (Inside Mount)

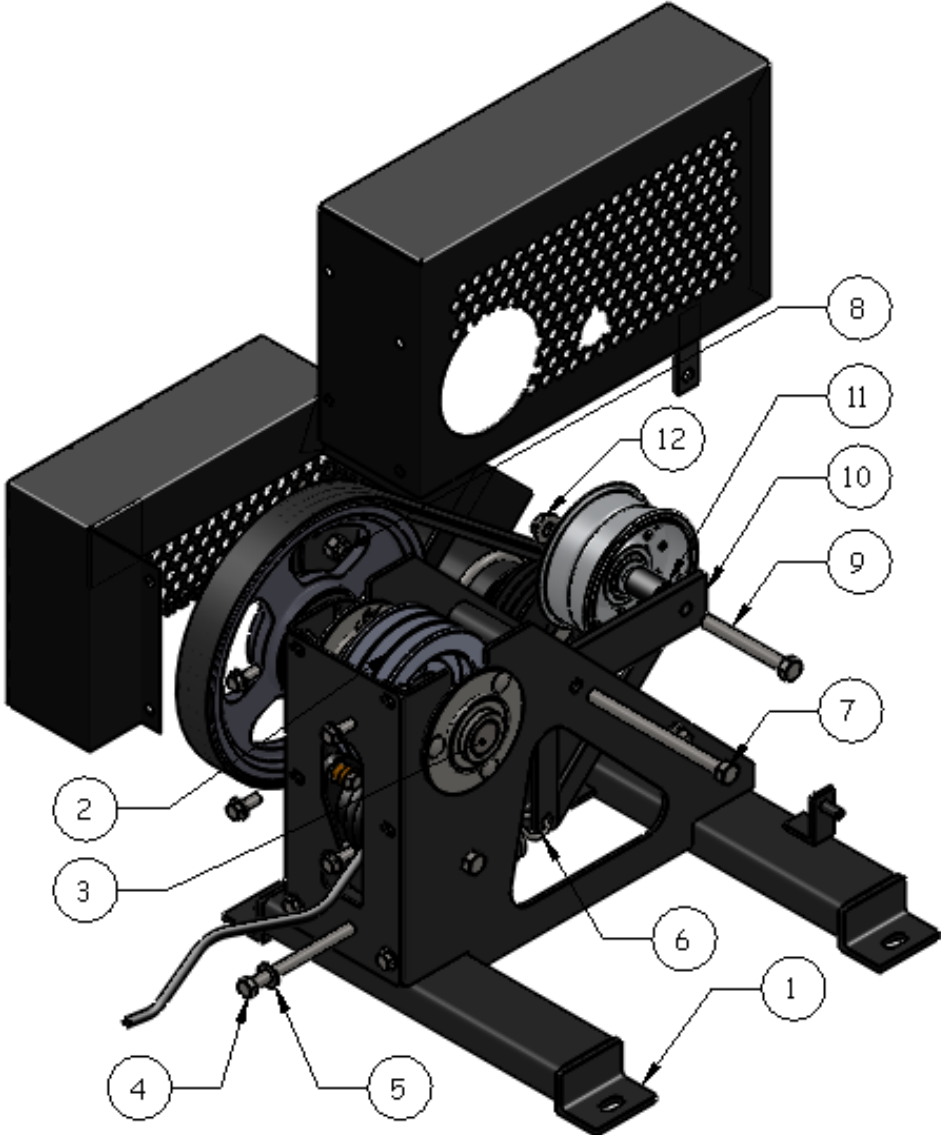

Item #	Part #	Description	Qty.
1	AWS0390	NH Chassis	1
2	AWS0516	5V x 5.90-3 Sheave	1
3	AWS0021	Secondary Shaft	1
4		7/16" NC x 5" Hex Bolt	1
5		7/16" Flat Washer	1
6	AWS0014	Extension Spring	1
7		1/2" NC x 6 1/2" Hex Bolt	1
8		1/2" NC Stover Locknut	1
9		1/2" NC x 4" Hex Bolt	1
10	AWS0531	NH Idler Arm	1
11	AWS0337	1/2" x 1 3/8" Spacer	1
12		1/2" NC Flanged Locknut	1

### NH Fixed Speed Chassis

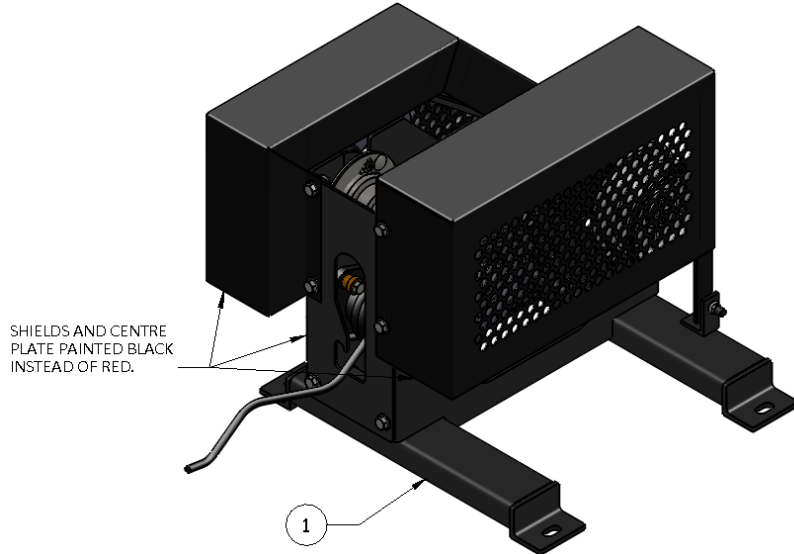

Item #	Part #	Description	Qty.
1	AWS0390	NH Chassis	1

### NH Variable Speed Chassis (Outside Mount)

Item #	Part #	Description	Qty.
1	AWS0390	NH Chassis	1
2	AWS0516	5V x 5.90-3 Sheave	1

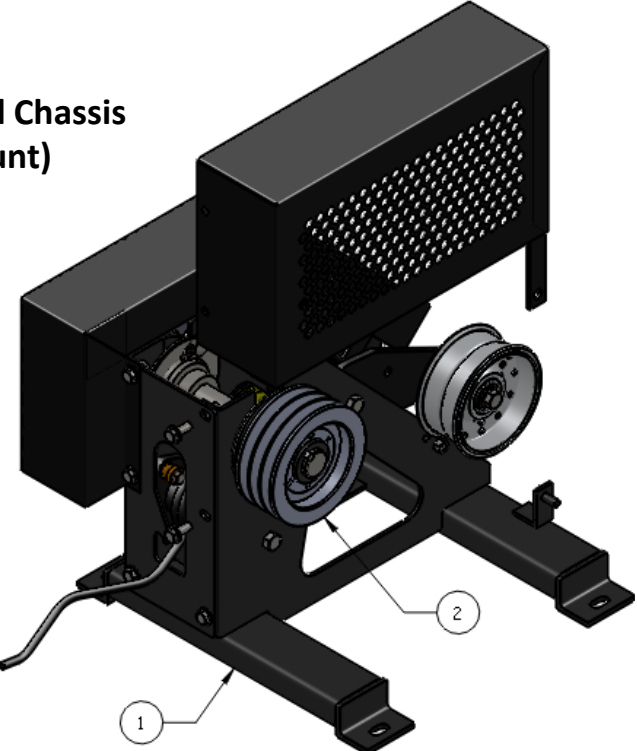

Note:

- Case/NH combine mounts share the same arrangements with some parts being interchanged for others.
- Only interchanged parts are labelled. See Case chassis assembly drawings for a more detailed drawing if needed.

## NH Fixed Speed Drive

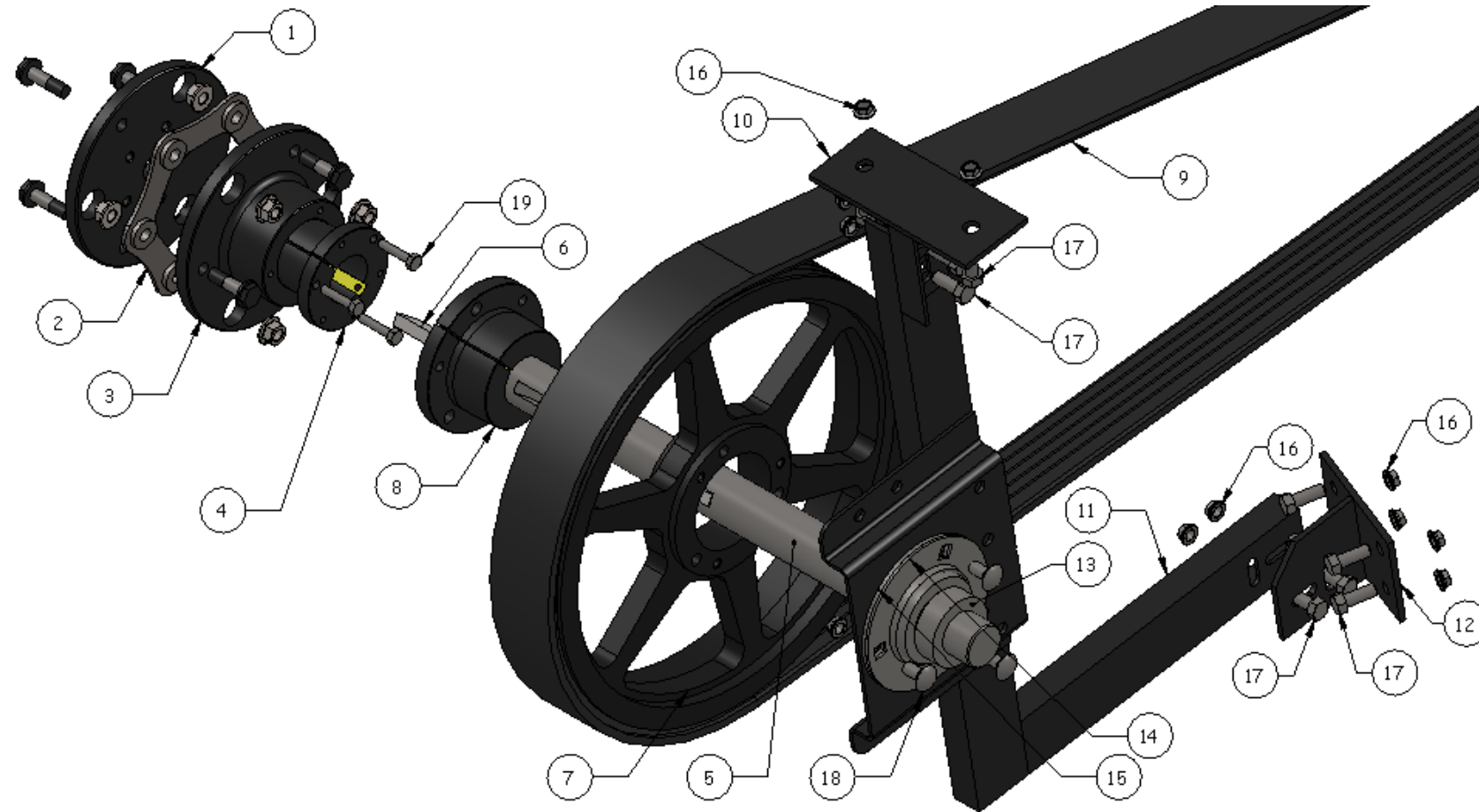

Item #	Part #	Description	Qty.
1	AWS0641	NH Drive Plate	1
2	AWS0640	Coupler Disc	1
3	AWS0642	Coupler Hub	1
4	AWS0436	1 1/2" SD Bushing	1
5	AWS0474	18.5" NH Shaft	1
6	AWS0426	3/8" #29 Woodruff Key	2
7	AWS0300	SV x 14.0-5 Sheave	1
8	AWS0437	1 1/2" SF Bushing	1
9	AWS0252	3C x 1120-5 Belt	1
10	AWS0472	Upper NH Fixed Support	1
11	AWS0471	NH Fixed Support	1
12	AWS0473	NH Fixed Lower Support	1
13	AWS0003	1 3/8" Bearing	1
14	AWS0001	PF207 Bearing Flange	1
15	AWS0420	Greasable Bearing Flange	1
16		3/8" NC Flanged Hex Nut	13
17		3/8" NC x 1" Bolt	10
18		3/8" NC x 3/4" Carriage Bolt	3
19		1/4" x 1 1/4" Hex Bolt	3

## NH Variable Speed Drive

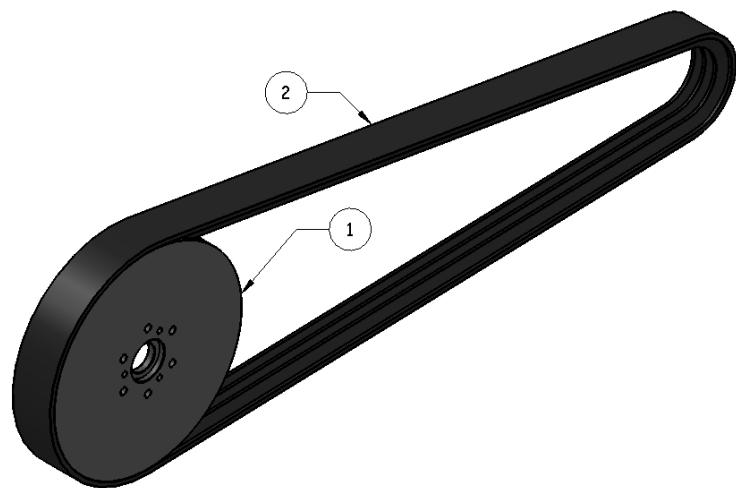

Item #	Part #	Description	Qty.
1	AWS0389	NH Sheave Mount	1
2	AWS0392	NH Var. Speed 5V x 1500 Belt	1

Outside Mount Used for:

NH 940/960/9040/9060/6090

Inside Mount Used for:

NH 970/9070/7090